



Caledonian

FIREFLEX **Fire Resistant** **Power Cables** **& Control Cables**

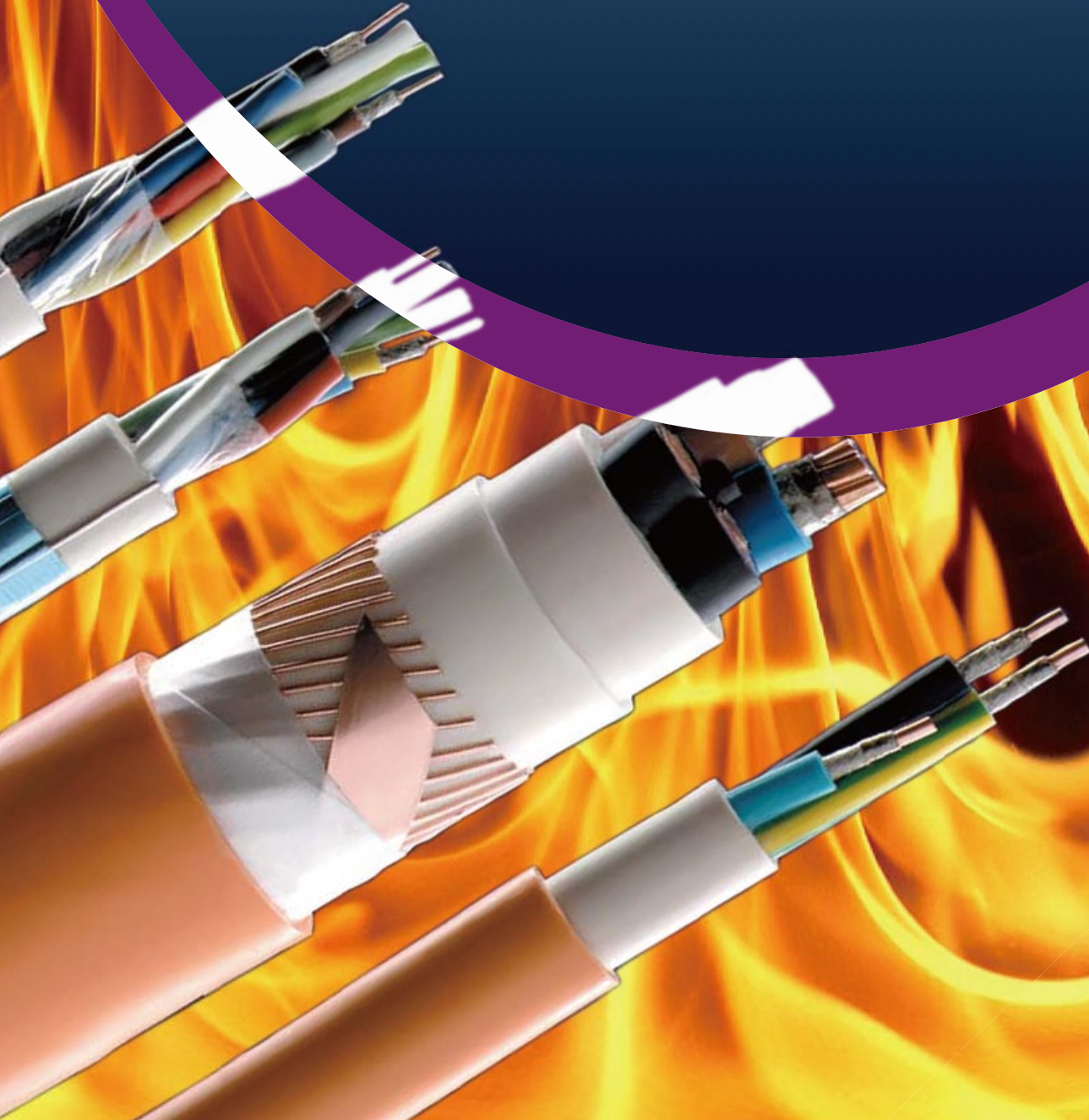

TABLE OF CONTENTS

Fire Resistant Power & Control Cables

450/750V Mica+LSZH Insulated Power Cables (Single Core).....	25
600/1000V Mica+LSZH Insulated Power Cables (Single Core).....	25
300/500V Mica+XLPE Insulated, LSZH Sheathed Power Cables (Single Core).....	30
600/1000V Mica+XLPE Insulated, LSZH Sheathed Power Cables (Single Core).....	33
600/1000V Mica+XLPE Insulated, Armoured LSZH Sheathed Power Cables (Single Core).....	38
300/500V Mica+XLPE Insulated, LSZH Sheathed Power Cables (2-4 Cores).....	42
600/1000V Mica+XLPE Insulated, LSZH Sheathed Power Cables (2-4 Cores & Multicore).....	46
300/500V SR Insulated Control Cables (2-4 Cores).....	53
300/500V SR Insulated & Overall Screened Control Cables (2-4 Cores & Multicore).....	60
300/500V Mica+SR Insulated & Overall Screened Control Cables (2-4 Cores & Multicore).....	64
50/750V SR Insulated Control Cables (2-5 Cores).....	69
450/750V SR Insulated & Overall Screened Control Cables (1-4 Cores & Multicore).....	73
600/1000V SR Insulated Flexibles Control Cables.....	81
Type Codes For Fire Resistant Power & Control Cables.....	86

FIRE RESISTANT CABLES

In all fire disasters, fire smoke, heat and toxic fumes are the main obstacles to safe evacuation of a building or area. A major contribution towards overcoming these hazards is the use of fire resistant and non-halogenated cables.

Caledonian fire resistant cables, branded under Fireflex, provide the following features:

- Fire resistance
- Long-term circuit integrity in a fire
- Minimum smoke emission
- Flame retardance
- Reduced fire propagation
- Zero halogen

Fireflex cables are mainly used in the wiring of:

- Fire resistant safety circuits
- Public address and emergency voice communication systems in high-rise building
- Control and instrumentation services in industrial, commercial and residential complexes
- High-temperature installation conditions

CABLE CONSTRUCTION

Fireflex cables have been developed to maintain circuit integrity in a fire and to ensure maximum safe evacuation of personnel with no detrimental effects like toxic gases or smoke.

Fireflex cables are constructed in the following typical design:

- Solid/stranded annealed copper conductor
- Glass mica tape/silicone rubber as flame barrier
- XLPE/silicone rubber as insulation
- LSZH/flame retardant PVC as sheath

Fireflex cables are offered in either single core, multicore or multi-pair constructions. The insulation material can be elastomeric(EPR, SR), thermosetting (XLPE, LSZH) or thermoplastic (EVA, PVC) to meet different stringent environment requirement. The cables may be armoured or braided, with or without metallic screen, depending on different applications. Caledonian can provide PE, PU, PVC, SHF1, SHF2 or LSZH materials as outer sheath for different applications.

INTERNATIONAL STANDARD COMPLIANCE

The fire resistant cables manufactured by caledonian comply with either one or combination of the following standards.

What is Fire Resistance

In a fire, the electrical systems must be able to keep functioning for a suitable length of time. This is particularly important for safety equipments used in emergency ventilation, emergency lighting, and



alarm systems, together with the power supply to transport facilities and elevators.

Fire resistance means that the cable or the cable system where the cable is installed is capable to continue to operate even in case of fire for a specific period of time from 30 to 180 minutes.

Circuit integrity (Insulation integrity) refers to tests for the cables only. This is denoted by FE180 in some European countries such as Germany and Belgium. Functional integrity refers to tests on cables and systems (ladders, cable tray, clamps etc). It is denoted by E30, E60, E90 indicating the cable resistance for 30, 60 and 90 minutes according to a specific test and different installation systems.

The functional integrity and the circuit integrity are not related in any way as regards their content. The former is a system test and the circuit (insulation) integrity is an individual cable test. The integrated system test for functional integrity is regarded as a technical benchmark in the cable industry.

DESIGN STANDARD IN ACCORDANCE WITH DIFFERENT STANDARDS

BS 7629-1:2008 – Electric cables. Specification for 300/500V fire resistant screened cables having low emission of smoke and corrosive gases when affected by fire. Multicore and multipair cables.

This standard apply to cables with thermosetting insulation of rated voltage 300/500V which conform to the performance requirements for cables required to maintain limited circuit integrity under those fire conditions of BS 6387 specified as B, W and X. Those cables are intended for use in fire alarm and emergency lighting applications.

The cables are suitable for operation at a maximum sustained conductor temperature of 70°C although the insulation is suitable for operation at higher temperatures. Use at a temperature not exceeding 90°C is allowed for terminations within an enclosure providing the cable conductor temperature outside the enclosure does not exceed 70°C.

The standards apply to cables with a rated voltage of 300/500V, and
-two, three and four-core circular cables with uninsulated circuit protective conductor
-7,12 or 19 core with an uninsulated drain wire
-1,2,5,10,20 pairs having a collective metallic layer and drain wire.

They contain a metallic layer which provides electrostatic screening.

BS 7846:2009 – Electric cables. Thermosetting insulated, armoured, fire resistant cables of rated voltage 600/1000V, having low emission to smoke and corrosive gases when affected by fire.

Some circuits requiring an equivalent level of fire resistance need to be designed for larger cables than are found in BS 7629-1. Such circuits may be for the main emergency supply, fire fighting lifts, sprinkler system and water pumps, smoke extraction fans, fire shutters or smoke dampers. These larger cables are standardized in BS 7846 which covers the size range and LSZH performance under BS 6724. Through the use of mica tape to supplement the insulation, the cables can pass BS 6387 CWZ and additionally the 'standard' or 'enhanced' grade as specified in BS 5839-1.

The cables are intended for use in fixed installations in industrial areas, buildings and similar

applications, where maintenance of power supply during a fire is essential and where the evolution of smoke and corrosive gases must be kept to a minimum.

The circuit integrity performance under fire conditions is assessed on the basis of various tests where resistance to fire, resistance to fire with water, and resistance to fire with mechanical shock are assessed separately or in combination. The cables are designated by the following categories:

Category F1- resistance to fire alone

Category F2- resistance to fire, resistance to fire with water, resistance to fire with mechanical shock, assessed separately.

Category F3- resistance to fire with mechanical shock and water assessed in combination.

The cables are wire armoured and

- two, three, four and five-core stranded copper conductor
- multicore auxiliary stranded copper conductor.

BS EN 60702 – Mineral insulated cables with a rated voltage not exceeding 750V.

BS EN 60702-1:2002 applies to mineral insulated general wiring cables with copper or copper alloy sheath and copper conductors and with rated voltage of 500V (light duty grade) and 750V (heavy duty grade). Provision is made for a corrosion resistant extruded outer covering over the copper sheath, when required. The standard sets out requirements for the optional outer covering, which includes requirements for halogen free covering and the thickness of the covering. The standard includes routine tests including a spark test on the outer covering. Sample tests includes such as flame retardance, emission of acidic and corrosive gases and smoke emission. Type tests such as fire resistance are included.

Mineral insulated cables are extremely resistant but rigid and a particular care has to be paid during installation to prevent moisture absorption by the mineral oxide.

500V grade cable includes the following conductor sizes:

- single and twin conductor cables up to 4mmsq csa
- three, four and seven conductor cables up to 2.5mmsq csa

750V grade cable provides for:

- single conductor cables up to 400mmsq csa
- two, three and four conductor cables up to 25mmsq csa
- seven conductor cables up to 4mmsq csa
- twelve conductor cables up to 2.5mmsq csa
- nineteen conductor cables up to 1.5mmsq csa





The fire related properties by the cable standards are summarised in the following table:

Cable Standard and type		Fire related properties	
BS 7629	Thermosetting insulated cables with limited circuit integrity when affected by fire	BS EN 50265-2-1 BS EN 50268-2 BS 6387 Cat B, W & X BS EN 50267-2-1	Tests on electric cables under fire conditions - single core cable. Measurement of smoke density of electric cables burning under defined conditions. Fire burning under defined conditions. Performance requirements for cables required to maintain integrity under fire conditions. Gases evolved during combustion of electric cables.
BS 7846	600/1000 V armoured electric cables having low emissions of smoke and corrosive gases when affected by fire	BS EN 50265-2-1 BS EN 50266-2-4 BS EN 50268-2 BS EN 50267-2-1 BS 7846 Cat F1, F2 or F3	Tests on electric cables under fire conditions - single core cable. Tests on electric cables under fire conditions - bunched cables. Measurement of smoke density of electric cables burning under defined conditions. Gases evolved during combustion of electric cables. Performance requirements for cables required to maintain integrity under fire conditions.
BS EN 60702	Mineral insulated cables with a rated voltage not exceeding 750V	BS EN 50265-2-1 BS EN 50268-2 (for zero-halogen coverings) BS EN 50267-2-1(for zero-halogen coverings) BS 6387 Cat C, W & Z	Tests on electric cables under fire conditions - single core cable. Measurement of smoke density of electric cables burning under defined conditions. Gases evolved during combustion of electric cables. Performance requirements for cables required to maintain integrity under fire conditions.



CODE OF PRACTICE IN ACCORDANCE WITH DIFFERENT STANDARDS

BS 5839-1:2002+A2:2008 (Fire detection and fire alarm systems for buildings. Code of practice for system design, installation, commissioning and maintenance).

This standard provides recommendations for the planning, design, installation, commissioning and maintenance of fire detection and fire alarm systems in and around building, other than dwellings. It recommends the use of fire resisting cables for mains power supply circuit and all critical signal path in such systems. It does not recommend whether or not a fire alarm system should be installed in any given premises. Cables are described in clause 26. This standard introduces two different levels of resistance of cables during a fire (standard and enhanced grade).



BS 5839-6:2004 - Fire detection and fire alarm systems for buildings. Code of practice for the design, installation and maintenance of fire detection and fire alarm systems in dwellings.

This code of practice covers every type of fire detection 'system', from a simple self-contained battery smoke alarm right through to major hard wired 24V systems.

BS 5839-6 also covers almost every conceivable type of premises, including:

- Bungalows
- Multi-storey houses
- Individual flats
- Individual maisonettes
- Mobile homes
- Individual sheltered accommodation
- Houses in multiple occupation (HMOs)
- NHS housing in the community

BS 5839-6 is primarily concerned with saving lives and reducing injuries. BS 5839-6 grades fire detection systems from Grade F up to Grade A. Generally speaking, the greater the fire risk and the more demanding the application, the more comprehensive the system needs to be.



for providing music and messages, are not guaranteed to work when there is an emergency. This is where the British Standard BS 5839 - 8:1998 on Voice Alarm comes into use, as it clearly defines the requirements of



a true VA system. A true VA system is a highly secure public address system which has the following features;

- All internal and external circuits are monitored for faults
- A minimum battery back up of 24 hours standby and 30 minutes alarm.
- A monitored secure link to a fire alarm panel
- A number of pre-recorded emergency messages
- Incorporates an emergency 'firemans' microphone

BS 5839-9:2011 - Fire detection and fire alarm systems for buildings. Code of practice for the design, installation, commissioning and maintenance of emergency voice communication systems.

An emergency voice communication systems(EVCS) is a fixed, secure, bi-directional, full duplex voice communication system to assist fire fighters in an emergency in high rise buildings or large sites where radio communication may not work, and covers the operation of both fire telephones and disabled refuge systems. Where both systems are fitted to a building, Bs5839-9 specifies these should be a single system.

BS 5266-1:2005 - Emergency lighting. Code of practice for the emergency lighting of premises.

The purpose of emergency lighting, anti-panic lighting and standby lighting is to ensure that the main fire exit routes from a building or open and high risk areas are sufficiently lit in the case of a mains failure, in order to allow persons to safely evacuate the areas or premises. Manual fire alarm points, first aid points, fire fighting and safety equipment should also be clearly lit, so that it can be clearly identified.

Cables installed for these systems have to withstand to fire for at least 60 minutes according to BS EN 50200.

BS 8519:2010- Selection and installation of fire resistant power and control cable systems for life safety and fire fighting applications. Code of practice.

BS 8519 was introduced specifically to apply only to large and complex buildings and has been widely welcomed within the industry. The new standard offers guidance for the selection of fire resistant power and control cables in life safety and firefighting systems such as smoke barriers, sprinkler systems, fire fighting and evacuation lift supplies. Consequently, BS 8519 should increase the protection of emergency and fire personnel, as well as evacuees who may be inside a large or complex building when fire breaks out.



CIRCUIT (INSULATION) INTEGRITY IN ACCORDANCE WITH DIFFERENT STANDARDS

Circuit (insulation) Integrity in accordance with IEC 60331

IEC 60331 specifies tests for electric cable for circuit integrity under fire conditions. It is divided in following parts that describe the test modes, the conditions, and the equipment to use. The test was originally carried out only in fire alone for a period of 180 minutes at a temperature of 750°C.

To better simulate the real fire conditions, with mechanical stresses due to the fall of materials and with the presence of water, the testing conditions have been modified by changing the duration, increasing the temperature of the flame and by adding mechanical stresses and water spray.

IEC 60331-1 ed 1.0 (2009-05)- Part 1: Test method for fire with shock at a temperature of at least 830°C for cables of rated voltage up to and including 0.6/1KV and with an overall diameter exceeding 20mm.

IEC 60331-2 ed 1.0 (2009-05)- Part 2: Test method for fire with shock at a temperature of at least 830°C for cables of rated voltage up to and including 0.6/1KV and with an overall diameter not exceeding 20mm.

IEC 60331-3 ed 1.0 (2009-05)- Part 3: Test method for fire with shock at a temperature of at least 830°C for cables of rated voltage up to and including 0.6/1KV tested in a metal enclosure.



IEC 60331-11 ed1.01 Consol. with am1 (2009-07) – Part 11: Apparatus – Fire alone at a flame temperature of at least 750°C.

IEC 60331-12 ed1.01 Consol. with am1 (2009-07) – Part 12: Apparatus – Fire with shock at a flame temperature of at least 830°C.

IEC 60331-21 ed1.0 (1999-04) – Part 21: Procedures and requirements – Cables of rated voltage up to and including 0.6/1KV.

IEC 60331-23 ed1.0 (1999-04) – Part 23: Procedures and requirements – Electric Data Cables.

IEC 60331-25 ed1.0 (1999-04) – Part 25: Procedures and requirements – Optic Fiber Cables.

IEC 60331-31 ed1.0 (1999-04) – Part 31: Tests for electric cables for fire conditions and shock-Circuit integrity. Procedures and requirements for fire with shock – Cables of rated voltage up to and including 0.6/1KV.

IEC 60331-21/60331-23 A sample of the cable length of 1200mm sustained by two metal rings is mounted horizontally in a special ventilated cabin. During the test, to the wire cores of cable a voltage of the nominal value is applied (for telecommunication cables equal to 110 V), thereby creating a closed electric circuit. The sample is subjected to an action of linear gas burner with a length of 500mm and the flame temperature equal to 750°C till 800°C. The time of the fire is 180 minutes. Result of the test is considered positive if at that time will not be considered a short circuit in the circuit being researched.

IEC 60331-25 details a method to assess the circuit integrity of optical fiber cables. The standard specifies a ribbon burner and the recommended flame temperature is 750°C. The optical power meter is zeroed and the changes in attenuation during the 180 minutes burner application period are monitored. The maximum change in attenuation (a change from zero) is recorded during the burner application period. In the 15 minutes period after the flame application, a maximum attenuation is also recorded. Result of the test is considered positive if at that time will not be considered a short



circuit in the circuit being tested.

IEC 60331-31 applies to the cables with a diameter greater than 20mm, and introduces the standards and procedures for testing of cables exposed to fire and mechanical shock (equipment according to 60331-12). The test sample provides cable fragment length at least 1500mm. Bent wire on the U-shaped with a radius equal to the smallest permissible by the manufacturer, is mounted on a metal assay ladder. During the study, through all the cable wires is passed current with rated voltage and these cables are subjected to fire during 120min, where fire source is a gas burner set in conformity with standards, as well the mechanical shock of the 5 minutes interval. Result of the test is considered positive if at that time will not be considered a short circuit in the circuit being tested.

Circuit (insulation) Integrity in accordance with BS 6387:1994

BS 6387:1994 specifies the requirements for cables required to maintain circuit integrity under fire conditions. This is the first standard to include also mechanical stress and water stress in the fire resistance test of electric cables. BS 6387 standard is still used in many countries. Being different from EN 50200, Its limits is to require three different tests on three different cable samples.



The fire resistant cables are categorized by a letter symbol (e.g. A) or series of symbols (e.g. CWZ) according to the requirements for fire resistance characteristics which they meet, the test temperature selected and the duration of the test for resistance to fire alone in according to BS 6387 as below:

The test provides the basis for the following categories:

Test	Category
(1) Resistance to fire alone 650°C for 3 hours 750°C for 3 hours 950°C for 3 hours 950°C for 20 minutes (short duration)	A B C S
(2) Resistance to fire with water Exposed to fire @ 650°C for 15 mins then exposed to fire @ 650°C with water for another 15 mins.	W
(3) Resistance to fire with mechanical shock Exposed to fire @ 650°C for 15 mins then exposed to fire @ 650°C with mechanical shock for 15 mins.	X
Exposed to fire @ 750°C for 15 mins then exposed to fire @ 750°C with mechanical shock for 15 mins.	Y
Exposed to fire @ 950°C for 15 mins then exposed to fire @ 950°C with mechanical shock for 15 mins	Z

The most common test comprises the three categories C, W and Z.

–Category C is a fire resistance test in which the cable is exposed to a fire at a temperature of 950°C with a duration of 3 hours. under realistic conditions.

– Category W is a fire and water resistance test in which the cable is exposed to a fire at a temperature of 650°C and then for another 15 minutes to fire with water that is poured over the area around the cable. This simulates effect of water from a sprinkler that is activated during the fire.

-Category Z is a fire and mechanical stroke test in which the cable is installed in a defined manner on a vertical wall with three cable clips and subject to heat from a gas burner; mechanical shock is simulated by striking the cable with a hammer. The cable is exposed to a fire at a temperature of 950°C and then for another 15 minutes to fire with mechanical shock at a frequency of 2 strikes per minute.

During testing in all three categories, the cable is connected to a 400V three-phase power supply protected with a 3 A fuse on each phase. The test is regarded as successful if none of the fuses blow during the test period.

Circuit (insulation) Integrity in accordance with EN 50200:2006

EN 50200:2006 defines method of test for resistance to fire of unprotected small cables (up to 20mm) for use in emergency circuits. In the adapted chamber is mounted a cable sample with a length of 1200mm, to which wire cores during the test a nominal value voltage is applied, creating thereby a closed circuit. During the test the cable is subjected to actions of the fire at conventional temperature 842°C and mechanical stroke for a specified period of time. The measured time of proper functioning of the cable corresponds to the so-called cable fire resistance class PH, which is also mentioned in the standard PN-B-02851-1 - Fire resistance tests of elements of buildings (Test method for thin wires with an outside diameter not greater than 20mm).



The test duration is expressed in minutes and is recorded in the following classification:

Test	Category
Flame exposure for 15 minutes	PH 15
Flame exposure for 30 minutes	PH 30
Flame exposure for 60 minutes	PH 60
Flame exposure for 90 minutes	PH 90
Flame exposure for 120 minutes	PH 120

EN 50200 annex E also foresees the water stress (fire, mechanical shock & water spray), as previously provided by BS 8434-1 standard. EN 50200 is similar to IEC 60331-2. Being different from BS 6387, EN 50200 test the same samples simultaneously stressed by the flame action, by the mechanical shock and by water spray.

Circuit (insulation) Integrity in accordance with EN 50362:2003

EN 50362:2003 / BS EN 50362:2003 / DIN EN 50362:2003 / CEI EN 50362:2003 (CEI 20-36/5-0) defines method of test for resistance to fire of larger unprotected power and control cables for use in emergency circuits. This standard provides the same tests foreseen by IEC 60331-31 standards. (Flame Temperature of 830°C).



Circuit (insulation) Integrity in accordance with BS 5839-1:2002

The new edition of BS 5839-1:2002 (Fire detection and fire alarm systems for buildings. Code of practice for system design, installation, commissioning and maintenance) describes two level of fire performance for fire rated cabling for fire alarm system: Standard Grade and Enhanced Grade. In order to confirm the compliance of the cable to both categories, BS 5839-1 refers to EN 50200 and BS 8434-2003 Part 1 & 2. (Method of tests for the assessment of fire integrity of electricity cables). These tests are carried out to verify the circuit integrity of small cables exposed to flame, mechanical shock and water in accordance with the new fire alarm code of practice.

Standard Grade clause 26.2d

Maintenance of circuit integrity:

BS 8434-1:2003 at 830°C for 30 minutes,

15 minutes with fire and mechanical shock plus

15 minutes with fire, mechanical shock and water.

BS EN 50200 PH30

30 minutes at 830°C with fire and mechanical shock

Enhanced Standard Grade clause 26.2e

Maintenance of circuit integrity:

BS 8434-2:2003 at 930°C for 120 minutes,

60 minutes with fire and mechanical shock plus

60 minutes with fire, mechanical shock and water.

BS EN 50200 PH120 (improved)

120 minutes at 830°C with fire and mechanical shock

Circuit (insulation) Integrity in accordance with BS 8434-1:2003 & BS 8434-2:2003 + A2:2009

BS 8434- Methods of test for assessment of the fire integrity of electric cables Part1: Test for unprotected small cables for use in emergency circuits - BS EN 50200 with the addition of water spray. Part 2: Test for unprotected small cables for use in emergency circuits- BS EN 50200 with a 930°C flame and with water spray.

BS 8434-1:2003 defines test which is equivalent to BS EN 50200 with a 830°C flame and water spray. The cable is stressed by the flame at 830°C with mechanical shocks for 15 minutes and further 15 minutes with the addition of water spray. BS 8434-2:2003 defines test which is equivalent to BS EN 50200 with a 930°C flame and water spray. The cable is stressed by the flame at 930°C with mechanical shocks for 60 minutes and further 60 minutes with the addition of water spray. The tests for BS 8434-2 have not been covered in the BS EN 50200 standard yet and are still in force.

Circuit (insulation) Integrity in accordance with BS 8491:2008

BS8491:2008 Method for assessment of fire integrity of large diameter power cables for use as components for smoke and heat control systems and certain other active fire safety systems. This standard is related to cables included in BS 7346-6 and certain other active fire safety systems. It is applicable to cables of rated voltage not exceeding 600/1000V and overall diameter greater than 20mm. The test method in BS 8491-2008 includes subjecting the cable under test to radiation via direct impingement corresponding to a constant temperature attack of 842°C, to direct mechanical impacts corresponding to a force of approximately 10N and to direct application of a water jet simulating a water fire fighting jet. The test method given in this standard includes three different test durations to allow testing of cables intended for different applications.

Circuit (insulation) Integrity in accordance with DIN VDE 0472-814

DIN VDE 0472-814:1991 - Testing of cables, wires and flexible cords; continuance of insulation effect under fire conditions.

A test fire is applied horizontally from a distance of 60cm to a single suspended cable during a specified time. The test is passed when there was continuous circuit integrity and no extremely increased attenuation values during and after the test respectively. For instance FE 90 cables can endure at least 90 minutes, „FE“ stands for flame exposure. The fire test with circuit integrity shows how many minutes a mechanically unstressed connection at a flame exposure of minimum 750°C keeps minimum insulation efficiency (circuit integrity) in a dry environment.

Similar standard is IEC 60331 (FE) and BS 6387 Cat C. This is a fire test for insulation integrity without any mechanical and water stress.

Circuit (insulation) Integrity in accordance with NBN C 30-004 (cat. F3)

NB N C 32 004 – Fire Resistance of electric cables. Classification and test method.

The cable is stressed by the flame at 900°C with mechanical shocks every 30 seconds for a duration of 3 hours. The cable is deemed to pass the test if the current leakage does not exceed 1 amp per conductor. The test must be passed by 4 successive samples.

Circuit (insulation) Integrity in accordance with SS299-1

SS299-1 Fire resistant cables - Performance requirements for cables required to maintain circuit integrity under fire conditions.

Circuit (insulation) Integrity in accordance with CEI 20-36/2-1

CEI 20-36/2-1 Tests for electric cables under fire conditions-Circuit integrity - Part 21: Procedures and requirements- Cables of rated voltage up to and including 0.6/1KV.

This is equivalent to IEC 60331-21.

Circuit (insulation) Integrity in accordance with CEI 20-36/4-0

CEI 20-36/4-0 Method of test for fire resistance of small cables unprotected for use in emergency circuits. This is equivalent to CEI EN 50200.

Circuit (insulation) Integrity in accordance with NF C32-070-2.3(CR1)

The cable is installed in a stainless steel conduit and heated to 920°C ± 20°C according to a specified time curve. A voltage of 500 V AC or 1,000 V AC respectively is applied to the cable. To simulate mechanical shock, a small hammer strikes the pipe at a frequency of 2 strikes / min.

SYSTEM CIRCUIT (FUNCTIONAL) INTEGRITY IN ACCORDANCE WITH DIFFERENT STANDARDS

System Circuit (functional) Integrity in accordance with DIN 4102-12

Maintaining the function of electrical cable during the fire, defined as the concept of cable system is characterized by the German DIN 4102, part 12. DIN 4101-12 is a testing for functional integrity of entire electrical cable systems together with fastener components and shall be considered as the most rigorous, but on the other hand, as most closely simulating the real fire conditions,





DIN 4102-12 defines the requirements and testing method for fire resistance of electric cable system required to maintain circuit integrity. The standard defines testing for the functionality of so-called cable set, which consists of a group set of power cables, telecommunications, data cables etc. to be fixed to the support structure consisting of channels, ladders, cable tray ,items to hang, handles, etc. Cables attached to this structure are powered by their work voltage. Functional integrity will be tested for short-circuit of insulation or discontinuity of any wire core.

DIN 4102-12 is a realistic fire-chamber testing with minimum dimensions 2 x 3 x 2.5 m. (width/length/height). A complete cable installation is tested under realistic conditions. The effects of thermal expansion and mechanical load during a fire are taken into account. The temperature must follow the standard fire curve (ETK): At E 90, the system is tested for 90 minutes, with a flame temperatures reaching up to 1000°C during the test. The cable is installed in a furnace and mounted with cable trays and cable clips with guides. A voltage of 400 V AC is applied to the cable (or 110 V AC for telecommunications cables)

There are three categories of function maintenance as follows:

E30 - cable system function maintenance in case of fire for 30 minutes

E60 - cable system function maintenance in case of fire for 60 minutes

E90 - cable system function maintenance in case of fire for 90 minutes

The numbers in each case designate the period of time for which the integrity of the power circuit must be maintained.

It is worth noting that duration of the cable operation under test is determined not only by design and selection of used cable materials, but also and often primarily, the construction and selection of supporting structure materials, which is subject to deformation in high temperatures, and these deformations in turn tighten the cables attached to the structure.

System Circuit (functional) Integrity in accordance with NBN 713 020

The test specifies fire performance of building materials and products. The cables are installed in 3 x 3 testing room They are installed on cable trays and undergo the flame action up to 1000°C. The cables are then classified according to the maximum time for resistance to fire (denoted by Rf1, Rf 1 1/2, Rf2 in which the number represents the time duration).

FLAME RETARDANCE IN ACCORDANCE WITH DIFFERENT STANDARDS

The following standards specify a method for flame propagation test for single core cables. The single cable sample undergoes the flame action of a bunsen burner. The test only lasts few minutes.

The IEC 60332-1 standards are taken over as EN standards and transferred to national standards Example: IEC 60332-1 becomes EN 60332-1 and introduced in Germany as DIN EN 60332-1.

Flame Retardance in accordance with EN 60332:2004

EN 60332:2004 Tests on electrical and optical cables under fire conditions. The standard applies to single insulated wires (cables) and requires a vertical flame test with a maximum flame climb of 450mm. The test lasts between 1 and 8 minutes, depending on the cable diameter.

EN 60332-1-1:2004 / BS EN 60332-1-1:2004 / IEC 60332-1-1:2004 / DIN EN 60332-1-1:2004 / VDE 0482-1-1:2005-06 Test on electrical and optical cables under fire conditions. Test for a vertical flame propagation fo a single insulated wire or cables.

EN 60332-1-2:2004 / BS EN 60332-1-2:2004 / IEC 60332-1-2:2004 / DIN EN 60332-1-2:2004 / VDE 0482-1-2:2005-06 / CEI 60332-1-2(CEI 20-35/1-2) Tests on electrical and optical fiber cables under fire conditions. Test for a vertical flame propagation for a single insulated wire or cable – Procedure for 1kW premixed flame.

This standard specifies a method of test for resistance to vertical flame propagation for a single insulated wire or cable. Part 1-1 specifies the test apparatus and Part 1-2 specifies the test procedure.

The cable sample is deemed to pass the test if the distance between the lower edge of the top support and the onset of charring is greater than 50mm. In addition, a failure shall be recorded if burning extends downward to a point greater than 540mm from the lower edge of the top support.

EN 60332-1-2:2004 specifies the use of 1kW premix flame and is for general use, except that the procedure may not be suitable for the testing of small insulated conductors or cables of less than 0.5mm sq cross section because the conductor melts before the test is completed, or for the testing of small optic fiber cables because the fiber will be broken before the test is completed. In this case, the procedure given by EN 60332-2-1/2 is recommended.

EN 60332-2-1:2004 / BS EN 60332-2-1:2004 / IEC 60332-2-1:2004 / DIN EN 60332-2-1:2004 / VDE 0482-2-1:2005-06 Tests on electrical and optical cables under fire conditions. Test for a vertical flame propagation for a single small insulated wire or cable.

EN 60332-2-2:2004 / BS EN 60332-2-2:2004 / IEC60332-2-2:2004 / DIN EN 60332-2-2:2004 / VDE 0482-2-2:2005-06 / CEI 60332-2-2 (CEI 20-35/2-2) Test on electric and optical fiber cables under fire conditions. Tests for vertical flame propagation for a single small insulated wire or cable. Procedure for diffusion flame.

This test applies to small dimensions cables.

This standard specifies a method of test for resistance to vertical flame propagation for a single insulated wire or cable. Part 2-1 specifies the test apparatus and Part 2-2 specifies the test procedure.

Flame Retardance in accordance with NF C32-070-2.1(C2)

NF C32-070:2001 Insulated conductors and cables for installation - Classification tests on conductors and cables with regard to fire behavior.

NF C32-070 2.1 Procedure for 1 kW pre-mixed flame.

The NF F 32070 2.1 (Category C2) and IEC 60332-1-2 are very similar. The sole difference is the time during which the flame is applied.

Flame Retardance in accordance with EN 50265-1:1999 (replaced by EN 60332)

EN 50265-1:1999 / BS EN 50265-1:1999 / DIN EN 50265-1:1999 / VDE 0482-265-1:1999-04– Common test methods for cables under fire conditions. Test for resistance to a vertical flame propagation for a single insulated conductor or cable. Apparatus (Replaced by EN 60332-1-1:2004 and EN 60332-2-1:2004).

EN 50265-2-1:1999 / BS EN 50265-2-1:1999 / DIN EN 50265-2-1:1999 / VDE 0482-265-2-1:1999-04 – Common test methods for cables under fire conditions. Test for resistance to a vertical flame



propagation for a single insulated conductor or cable. Part 2-1: Procedure 1kW pre-mixed flame (Replaced by EN 60332-1-2:2004).

EN 50265-2-2:1999 / BS EN 50265-2-2:1999 / DIN EN 50265-2-2:1999 / VDE 0482-265-2-2:1999-04 – Common test methods for cables under fire conditions. Test for resistance to a vertical flame propagation for a single insulated conductor or cable. Part 2-2: Procedure Diffusion flame (Replaced by EN 60332-2-2:2004).



Flame Retardance in accordance with BS 4066 Part 1 & 2 (replaced by EN 60332)

BS 4066-2:1980 (superseded) – Tests on electric cables under fire conditions. Method of test on a single vertical insulated wire or cable.

This standard is no longer in force and is replaced by BS EN 50265-2-1 which was also superseded by BS EN 60332-1:2009.

Flame Retardance in accordance with NBN C 30-004 (cat. F1)

NBN C 32-004 specifies a method of test for measuring the vertical flame propagation characteristics of a single wire or cable. The cable specimen is deemed to have passed the test and categorized as F1 if after burning has ceased, the charred or affected portion does not reach within 50mm of the lower edge of the top clamp which is equivalent to 425mm above the point of flame application.

Flame Retardance in accordance with IEEE 383

In the IEEE 383 test, cables are supported by a one foot wide vertical rack eight feet high. The cables are positioned in the centre six inches of the rack, spaced one-half diameter apart. The rack is centered in an eight foot enclosure. A ten inch ribbon burner ignites the cable with a 21 kW (70000 BTU). The burner is positioned 2 feet above the floor and 9 to 12 inches of cables are exposed to direct flames for 20 minutes. Cables on which flame extends above the top of the 8 foot rack fail the test.

REDUCED FIRE PROPAGATION IN ACCORDANCE WITH DIFFERENT STANDARDS

These standards specify a method for fire propagation test for vertically mounted bunched cables. These tests simulate the chimney effect in vertical installation of bunch of cables. A certain number of cable sections with a length of 3.5 m is fastened to a vertical ladder in an adapted chamber. The amount of combustible materials for cables and duration of flame application depends on the category the cable has to meet.

Resistance of the wires bundle arranged vertically to the spread of the flame should be such that after a certain time and stopping the source of ignition, flame is extinguished by itself and the length of charred fragments will not exceed 2.5 m in height measured above the lower edge of the burner.



Reduced Fire Propagation in accordance with IEC 60332-3

This test is the most common one to verify the behaviour of a cables for the fire propagation. The cables are installed on a bunch of vertical ladder inside a metal cabinet and undergo the action of a ribbon flame at 750°C. The standard is subdivided in several parts that differ one from the other for the quantity of cable to be installed, the installation mode and the flame application time.

EN 60332-3-10:2009 / BS EN 60332-3-10:2009 / IEC 60332-3-10 ed1.1 / DIN EN 60332-3-10:2009 / VDE 0482-332-3-10:2010-08 – Common test methods for cables under fire conditions. Tests on electric and optical fiber cables under fire conditions - Part 3-10: Test for vertical flame spread of vertically mounted bunched wires or cables.

EN 60332-3-21:2009 / BS EN 60332-3-21:2009 / IEC 60332-3-21 ed1.1 / DIN EN 60332-3-21 / VDE 0482-332-3-21:2010-08 / CEI EN 60332-3-21:2009 (CEI 20-22/3-1)– Procedures. Tests on electric and optical fiber cables under fire conditions - Part 3-21: Test for vertical flame spread of vertically-mounted bunched wires or cables - Category A . F/R

- Installation In one layer (front).
- Installation In two layers (front and rear)
- The quantity of the Installed cable is equal to 7 litres/m of combustible materials for cables
- The time of application of the flame is 40 minutes

EN 60332-3-22:2009 / BS EN 60332-3-22:2009 / IEC 60332-3-22 ed1.1 / DIN EN 60332-3-22:2009 / VDE 0482-332-3-22:2010-08 / CEI EN 60332-3-22:2009 (CEI 20-22/3-2)– Procedures. Tests on electric and optical fiber cables under fire conditions - Part 3-22: Test for vertical flame spread of vertically-mounted bunched wires or cable - Category A

- Installation In one layer (front).
- The quantity of the installed cable is equal to 7 litres/m of combustible materials for cables
- The time of application of the flame is 40 minutes

EN 60332-3-23:2009 / BS EN 60332-3-23:2009 / IEC 60332-3-23 ed1.1 / DIN EN 60332-3-23:2009 / VDE 0482-332-3-23:2010-08 / CEI EN 60332-3-23:2009 (CEI 20-22/3-3)– Procedures. Tests on electric and optical fiber cables under fire conditions - Part 3-23: Test for vertical flame spread of vertically-mounted bunched wires or cables - Category B

- Installation In one layer (front).
- The quantity of the installed cable is equal to 3.5 litres/m of combustible materials for cables
- The time of application of the flame is 40 minutes

EN 60332-3-24:2009 / BS EN 60332-3-24:2009 / IEC 60332-3-24 ed1.1 / DIN EN 60332-3-24:2009 / VDE 0482-332-3-24:2010-08 / CEI EN 60332-3-24:2009 (CEI 20-22/3-4) – Procedures. Tests on electric and optical fiber cables under fire conditions - Part 3-24: Test for vertical flame spread of vertically-mounted bunched wires or cables - Category C

- Installation In one layer (front).
- The quantity of the installed cable is equal to 1.5 litres/m of combustible





materials for cables

-The time of application of the flame is 20 minutes

EN 60332-3-25:2009 / BS EN 60332-3-25:2009 / IEC 60332-3-25 ed1.1 / DIN EN 60332-3-25: 2009 / VDE 0482-332-3-25:2010-08 / CEI EN 60332-3-25:2009 (CEI 20-22/3-5)– Procedures. Tests on electric and optical fiber cables under fire conditions - Part 3-25: Test for vertical flame spread of vertically-mounted bunched wires or cables - Category D

-Installation In one layer (front).

-The quantity of the installed cable is equal to 0.5 litres/m of combustible materials for cables

-The time of application of the flame is 20 minutes.

Summary of test condition:

IEC	60332-3-21		60332-3-22		60332-3-23		60332-3-24		60332-3-25	
BS EN 50266	50266-2-1		50266-2-2		50266-2-3		50266-2-4		50266-2-5	
CEI	20-22/3-1		20-22/3-2		20-22/3-3		20-22/3-4		20-22/3-5	
Category	AF/R		A		B		C		D	
Conductor cross-sections(mm²)	>35		>35	≤35	>35	≤35	>35	≤35	>35	≤35
NMV(litres per metre of cable)	7		7		3.5		1.5		0.5	
Minimum length of test pieces(m)	3.5		3.5		3.5		3.5		3.5	
Standard ladder (500 mm wide): • number of layers • maximum width of test sample	1front+1rear 300mm	≥1front 300mm	1front 300mm	- -	≥1front 300mm	1front 300mm	≥1front 300mm	1front 300mm	≥1front 300mm	
Wide ladder (800 mm wide): • number of layers • maximum width of test sample	- -	- -	- -	1front 600mm	- -	- -	- -	- -	- -	
Positioning of test pieces	Spaced 0.5×Diameter cable (Max.20mm)	Touching	Spaced 0.5×Diameter cable (Max.20mm)		Touching	Spaced 0.5×Diameter cable (Max.20mm)	Touching	Spaced 0.5×Diameter cable (Max.20mm)	Touching	
Number of burners	1	1	1	2	1	1	1	1	1	
Ladder mounting	Front and rear	Front, Wider ladder for larger cables			Front		Front		Front	
Flame application time(min)	40	40	40		40		40		40	
Test conditions	Wind speed: <8 m/s; Temperature: 5°C - +40°C									
Extent of the charred portion	≤2.5m above the bottom edge of the burner, neither at the front nor at the rear of the ladder.									

Reduced fire propagation in accordance with NF C32-070-2.2(C1)

NF C32-070 :2001 Insulated conductors and cables for installation.

-Classification tests on conductors and cables with regard to fire behavior.

A 1600mm vertically installed bundled of cable is exposed to the effects of a radiating oven (approx 830°C) and forced ventilation. Pilot flames arranged above the oven burn off the emitted gases. The test duration is 30 minutes, with the ventilation stopped for every 10 minutes during the flame application period. The cable sample is classified under Category C1 according to NF F 32070-2.2 if the carbonised part of the cable sample does not extend more than 0.8m above the upper base of the oven.

Depending on the damaged length, they can be further classified into 4 classes A, B, C and D according to NF F 16-101 as follows:

Category	Test Result
A	No damaged length from top of the oven in upper position.
B	Damaged length from top of oven in upper position not extending more than 50mm.
C	Damaged length from top of oven in upper position not extending more than 300mm
D	Damaged length from top of oven in upper position not extending above the top of the chimney

Reduced Fire Propagation in accordance to EN 50266-1, EN 50266-2-2, EN 50266-2-3, EN 50266-2-4.

EN 50266-1:2001 / BS EN 50266-1:2001 / DIN EN 50266-1:2001 / VDE 0482-266-1:2001-09– Common test methods for cables under fire conditions. Test for vertical flame spread of vertically mounted bunched wires or cables - Part 1: Apparatus (Replaced by EN 60332-3-10:2009)

EN 50266-2-1:2001 / BS EN 50266-2-1:2001 / DIN EN 50266-2-1:2001 / VDE 0482-266-2-1:2001-09 / CEI EN 50266-2-1– Common test methods for cables under fire conditions. Test for vertical flame spread of vertically mounted bunched wires or cables - Part 2-1 : Procedures. Category A F/R (Replaced by EN 60332-3-21:2009)

EN 50266-2-2:2001 / BS EN 50266-2-2:2001 / DIN EN 50266-2-2:2001 / VDE 0482-266-2-2:2001-09 / CEI EN 50266-2-2– Common test methods for cables under fire conditions. Test for vertical flame spread of vertically mounted bunched wires or cables - Part 2-2: Procedures. Category A (Replaced by EN 60332-3-22:2009)

EN 50266-2-3:2001 / BS EN 50266-2-3:2001 / DIN EN 50266-2-3:2001 / VDE 0482-266-2-3:2001-09 / CEI EN 50266-2-1– Common test methods for cables under fire conditions. Test for vertical flame spread of vertically mounted bunched wires or cables - Part 2-3: Procedures. Category B (Replaced by EN 60332-3-23:2009)



EN 50266-2-4:2001 / BS EN 50266-2-4:2001 / DIN EN 50266-2-4:2001 / VDE 0482-266-2-4:2001-09 / CEI EN 50266-2-4:2001 – Common test methods for cables under fire conditions. Test for vertical flame spread of vertically mounted bunched wires or cables - Part 2-4: Procedures. Category C (Replaced by EN 60332-3-24:2009).



Reduced Fire Propagation in accordance with BS 4066-3

BS 4066-3:1994 (superseded) – Tests on electric cables under fire conditions. Tests on bunched wires or cables.

This standard is no longer in force and is replaced by the BS EN 50266-1:2001

Reduced Fire Propagation in accordance with NBN C 32-004 (F2)

NBN C 32-004 specifies a method of test for measuring the vertical flame propagation characteristics of a bunch of cables. The cable specimen is deemed to have passed the test and categorized as F2 if after burning has ceased, the extent of charred or affected portion does not reach a height exceeding 2.5m above the bottom edge of the burner.

HALOGEN CONTENT TEST IN ACCORDANCE WITH DIFFERENT STANDARDS

In the event of a fire, many fumes are produced. This test is concerned with the possibilities of corrosive acid gases being released from halogen containing cables and the damage such cables can cause (to equipments). These standards specify a method for determination of the amount of halogen acid gas, evolved during combustion of compound.



Halogen Content Test in accordance with EN 50267-2-1

EN 50267-2-1:1998 / BS EN 50267-2-1:1999 / DIN EN 50267-2-1:1999 / VDE 0482-267-2-1:1999-04 / CEI EN 50267-2-1:1999 (CEI 20-37/2-1) Common test methods for cables under fire conditions- Test on gases evolved during combustion of materials from cables- Part 2-1: Procedures. Determination of the amount of halogen acid gas.

This part of the standard defines the method to measure the amount of halogen acid evolved and which should be expressed in hydrochloric acid. The amount of halogen acid contained in the test solution is determined by a titration method.

If the cables are described as zero halogen or halogen free, it is recommended that the hydrochloric acid yield should be less than 0.5%.

Halogen Content Test in accordance with IEC 60754-1

IEC 60754-1 ed 2.0 Common test methods for cables under fire conditions. Test on gases evolved during combustion of materials from cables. Part 1: Procedures. Determination of the amount of halogen acid gas.

Basically, this is same as EN 50267-2-1.

Halogen Content Test in accordance with BS 6425-1

BS 6425-1:1990(superseded): Test on gases evolved during the combustion of materials from cables. Method for determination of amount of halogen acid gas evolved during combustion of polymeric materials taken from cables.

This standard is no longer in force and is replaced by the EN 50267-2-1.

ACID GAS EMISSION TEST IN ACCORDANCE WITH DIFFERENT STANDARDS

The following standards specify a method for determination of acidity of gas evolved during

combustion of cables by measuring PH and conductivity. This test allows to determine the corrosivity of the acid gases generally halogens, that develop during the electric cable combustion.

Acid Gas Emission Test in accordance with EN 50267-2-2

EN 50267-2-2:1999 / BS EN 50267-2-2:1999 / DIN EN 50267-2-2:1999 / VDE 0482-267-2-2:1999-04 / CEI EN 50267-2-2:1999 (CEI 20-37/2-2). Common test methods for cables under fire conditions- Test on gases evolved during combustion of materials from cables- Part 2-2: Procedures. Determination of degree of acidity of gases for materials by measuring PH and conductivity. The standard states that the pH and the conductivity of a test solution should be measured, using calibrated PH and conductivity meters.

If the cables are described as zero halogen or halogen free, it is recommended that at least both of the following requirements should be met for each of the individual materials of a cable:

- The PH value should not be less than 4.3 when related to 1 litre of water
- The conductivity should not be less than 10us/mm when related to 1 litre of water



EN 50267-2-3:1999 / BS EN 50267-2-3:1999 / DIN EN 50267-2-3:1999 / VDE 0482-267-2-3:1999-04 / CEI EN 50267-2-3:1999 (CEI 20-37/2-3). Common test methods for cables under fire conditions- Test on gases evolved during combustion of materials from cables- Part 2-3:Procedures. Determination of degree of acidity of gases for cables by determination of the weighted average of pH and conductivity.

The standard states that the pH and the conductivity of a test solution should be measured, using calibrated pH and conductivity meters. The results from the different components of the cable are then weighted.

Acid Gas Emission Test in accordance with IEC 60754-2

IEC 60754-2 ed1.0 Test on gases evolved during combustion of electric cables - Part 2 : Determination of degree of acidity of gases evolved during combustion of materials taken from electric cables by measuring pH and conductivity.

Acid Gas Emission Test in accordance with NF C32-074

NF C32-074 Common test methods for cables under fire conditions - Test on gases evolved during combustion of materials from cables. This standard is equivalent to IEC 60754-2

Acid Gas Emission Test in accordance with BS 6425-2

BS 6425-2:1993 (superseded) Test on gases evolved during the combustion of materials from cables. Determination of degree of acidity (corrosivity) of gases by measuring pH and conductivity.

This standard is no longer in force and is replaced by the EN 50267-2-2:1999.

Acid Gas Emission Test in accordance with DIN VDE 0472-813 / VDE 0472-813:1994

DIN VDE 0472-813 / VDE 0472-813:1994 Corrosivity of combustion gases.



The standards are no longer in force and are replaced by the EN 50267-2-2 & VDE 0482-267-2-2.

SMOKE DENSITY TEST IN ACCORDANCE WITH DIFFERENT STANDARDS

The smoke density measurement taken from a material under fire conditions gives an indication of the visibility through the smoke. This is important as reduced visibility in a real fire situation makes it more difficult to escape from the fire thus increasing the threat to human life from the toxic gas, fumes and heat.

The following standards specify the method for measuring the generation of smoke from cables during fire.

Smoke Density Test in accordance with IEC 61034-1 & IEC 61034-2

IEC 61034-1:2005 / EN 61034-1:2005 / BS EN 61034-1:2005 / DIN EN 61034-1:2006 / VDE 0482-1034-1:2006 Measurement of smoke density of cables burning under defined conditions. Part 1: Test apparatus

IEC 61034-2:2005 / EN 61034-2:2005 / BS EN 61034-2:2005 / DIN EN 61034-2:2006 / VDE 0482-1034-2:2006 / CEI EN 61034-2:2006 (CEI 20-37/3-1) Measurement of smoke density of cables burning under defined conditions.

Part 2: Test procedure and requirements.



The standard specifies a method of measurement of smoke density of cables. Part 1 specifies the test apparatus and Part 2 specifies the test procedure.

The test is usually performed inside a chamber of 3m x3m x3m and the test is sometimes described as 3 metre cube test. The test is performed by monitoring the transmittance reduction of a white light beam, running from one side of the chamber to the other, at a set height, thus monitoring the build up of smoke inside the chamber. The minimum percentage of light transmittance is often used to determine if the cable has passed or failed the test, often a minimum light transmittance of 60% is applied in order to classify a cable as low smoke.

Smoke Density Test in accordance with NF C32- 073

NF C32 073 Common test methods for cables under fire conditions.

- Measurement of smoke density of cables burning under defined conditions.

This standard is equivalent to IEC 61034-2

Smoke Density Test in accordance with BS 7622-1 & BS 7622-2

BS 7622-1:1993 (superseded) – Measurement of smoke density of electric cables burning under defined conditions. Test apparatus.

BS 7622-2:1993 (superseded) – Measurement of smoke density of electric cables burning under defined conditions. Test procedure and requirements.

The standards are no longer in force and were replaced by the EN 50268-1:2000 and EN 50268-2:2000 even though they too were superseded by EN 61034-1:2005 and EN 61034-2:2005.

Smoke Density Test in accordance with EN 50268-1 & EN 50268-2

EN 50268-1:2000 / BS EN 50268-1:2000 / DIN EN 50268-1:2000 / VDE 0482-268-1:2000 (superseded) – Common test methods for cables under fire conditions. Measurement of smoke density of cable burning under defined conditions. Part 1: Apparatus

EN 50268-2:2000 / BS EN 50268-2:2000 / DIN EN 50268-2:2000 / VDE 0482-268-2:2000 (superseded) – Common test methods for cables under fire conditions. Measurement of smoke density of cable burning under defined conditions. Part 2: Procedure.

The standards are no longer in force and are replaced by the EN 61034-1:2005 and EN 61034-2:2005. Although these standards have been withdrawn, they are still called upon in some specification documents such as in the London Underground specification 1-085.

Smoke Density Test In Accordance with DIN VDE 0472-816 / VDE 0472-816:1994

DIN VDE 0472-816/VDE 0472-816:1994 Testing of cables, wires and flexible cords. Smoke Density.

The standards are no longer in force and are replaced by the EN 50268-1, VDE 0482-268-1, EN 50268-2 & VDE 0482-268-2 which are also replaced by the EN 61034-1:2005 and EN 61034-2:2005.

OXYGEN INDEX TEST IN ACCORDANCE WITH DIFFERENT STANDARDS

The oxygen index is defined as the minimum concentration of oxygen, expressed as volume percentage, in a mixture of oxygen and nitrogen that will just support combustion of a material initially at room temperature under specified test conditions.

Oxygen Index Test in accordance with ASTM D 2863

ASTM D 2863-10 Measuring the minimum oxygen concentration to support candle-like combustion of plastics (Oxygen Index).



The test is performed in accordance with the procedure specified in ASTM 2863-95 using test piece cut from the outer sheath of the cable. The apparatus holds a small specimen which is clamped vertically in a tube in an atmosphere where the relative concentration of oxygen and nitrogen can be changed. The aim is to test the flammability of the sample with a small pilot flame to find the minimum oxygen concentration required to just sustain combustion of the sample.

Oxygen Index Test in accordance with ISO 4589-2

ISO4589-2:1996 Determination of burning behaviour by oxygen index Part 2: Ambient temperature test.

Specimens measuring 100mm long by 6mm wide are used for testing. The test is performed in accordance with the procedure specified in the standard.

TEMPERATURE INDEX TEST IN ACCORDANCE WITH DIFFERENT STANDARDS

This is a test for assessing the performance of a material when it is tested in accordance with BS2782: Part 1: Method 143a and 143b. The oxygen index of a material will drop when the temperature rises. When the temperature rises and the oxygen index drops to 21%, the material will burn





automatically. This temperature is defined as temperature index. For example, the oxygen index of the coal at room temperature is 50% and when the temperature climbs to 150°C, its oxygen index drops to 21°C and the coal will burn by itself automatically. The temperature index of the coal is defined as 150°C. In general, the temperature index of fire retardant cable exceeds 250°C.

Temperature Index Test in accordance with BS 2782

BS 2782: Part 1:1989 Method 143a and 143b Temperature of materials. Determination of flammability.

Specimens measuring nominally 100mm long by 6.5mm wide by 3mm thick are used for testing. The specimens are then tested in accordance with the test procedure specified in the standard.

Temperature Index Test in accordance with ISO 4589-3

ISO4589-3:1996 Determination of burning behaviour by oxygen index Part 3: Elevated temperature test.

Specimens measuring 100mm long by 6mm wide are used for testing. The test is performed in accordance with the procedure specified in the standard.

TOXICITY TEST IN ACCORDANCE WITH DIFFERENT STANDARDS

Toxicity test in accordance with NES 02-713

Measuring a fume from a material exposed to a controlled fire conditions gives an indication of the fumes which may be produced in a real fire situation. A standard method of test for determining the toxicity of materials under fire condition is Defense Standard NES 02-713- Toxicity. This method gives the level of toxicity of the fumes produced from the material under test. During the test, the test specimen is heated via direct flame application at 1150°C.

The flame is applied via a bunsen burner with a flame height of between 100mm and 125mm formed with a methane gas and an external supply of compressed air. The specimen toxicity is determined from accurate pre-analysis weight (4pp) colorimetric tubes and ion chromatography.

The test may determine the following species: Hydrogen Bromide, Hydrochloric Acid, Hydrogen Fluoride, Formaldehyde, Nitrous gases, Carbon Monoxide, Carbon Dioxide, Acrylonitrile, Phenol, Hydrogen Sulphide, Sulphur Dioxide, Hydrocyanic Acid, Ammonia. The concentration in ppm for each gas detected are provided. The toxicity index of the specimens summates the toxic gases, taking into account of their level of danger to humans. The smaller the toxicity index, the better the product. A limit of 5 is often applicable.

Toxicity test in accordance with NF C 20-454

NF C 20-454 base environmental testing procedures. Fire behaviour. Analysis and titration of gases evolved during pyrolysis or combustion of materials used in electrotechnics. Exposure to abnormal heat or fire. Tube furnace method.

The test defined by this standard serves to define the conventional toxicity index (cti) of the gases emitted by the insulating or sleeving materials during combustion at 800°C.



Toxicity test in accordance with NF X 70-100

NF X 70-100 Fire Tests; Analysis of gaseous effluents.

The test is conducted within a tube furnace where the temperature is set at either 400°C, 600°C, 800°C (commonly 600°C is used for most of the materials or 800°C for some electrical products) for 40 minutes throughout the test by analysis of the toxicity index of the gases including CO, CO₂, HCL, HBr, HCN, HF and SO₂.



450/750V Mica+LSZH Insulated Power Cables (Single Core)

FFX100 07mZ1-R (CU/MGT+LSZH 450/750V Class 2)

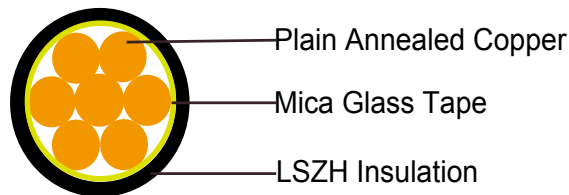
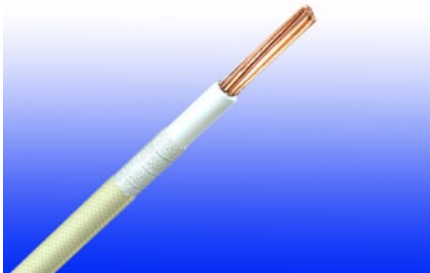

APPLICATION

This cable is used in fire extinguishing systems, sprinklers, control panels, and exit lights in high-rise buildings, hotels, hospitals, sub-ways, and public facilities.

STANDARDS

Basic design to BS 7211

FIRE PERFORMANCE

Circuit Integrity	IEC 60331-21; BS 6387 CWZ; DIN VDE 0472-814(FE180); CEI 20-36/2-1; SS299-1; NBN C 30-004 (cat. F3); NF C32-070-2.3(CR1)
System Circuit Integrity	DIN 4102-12, E30 depending on lay system
Flame Retardance (Single Vertical Wire Test)	EN 60332-1-2; IEC 60332-1-2; BS EN 60332-1-2; VDE 0482-332-1 ; NBN C 30-004 (cat. F1); NF C32-070-2.1(C2); CEI 20-35/1-2; EN 50265-2-1*; DIN VDE 0482-265-2-1*
Reduced Fire Propagation (Vertically-mounted bundled wires & cable test)	EN 60332-3-24 (cat. C); IEC 60332-3-24; BS EN 60332-3-24; VDE 0482-332-3; NBN C 30-004 (cat. F2); NF C32-070-2.2(C1); CEI 20-22/3-4; EN 50266-2-4*; DIN VDE 0482-266-2-4
Halogen Free	IEC 60754-1; EN 50267-2-1; DIN VDE 0482-267-2-1; CEI 20-37/2-1 ; BS 6425-1*
No Corrosive Gas Emission	IEC 60754-2; EN 50267-2-2; DIN VDE 0482-267-2-2; CEI 20-37/2-2 ; BS 6425-2*
Minimum Smoke Emission	IEC 61034-1&2; EN 61034 -1&2; DIN VDE 0482-1034-1&2; CEI 20-37/3-1&2; EN 50268-1&2*; BS 7622-1&2*
No Toxic gases	NES 02-713; NF C 20-454

Note: Asterisk * denotes superseded standard.

VOLTAGE RATING

450/750V

CABLE CONSTRUCTION

Conductor: Plain annealed copper wire, stranded according to IEC 60228 class 2

Fire Barrier: Mica glass tape

Insulation: Thermoplastic LSZH compound type LTS3 as per BS 7655-6.1 (Thermosetting LSZH compound type SW2-SW4 as per BS 7655-2.6 can be offered.). UV resistance, hydrocarbon resistance, oil resistance, anti rodent and anti termite properties can be offered as option.

COLOUR CODE

Insulation Colour as per BS7671

	With Earth Conductor	Without Earth Conductor
2Cores	-	Brown, Blue
3Cores	Yellow/Green, Brown, Blue	Brown, Gray, Black
4Cores	Yellow/Green, Brown, Gray, Black	Brown, Gray, Black, Blue
5Cores	Yellow/Green, Brown, Gray, Black, Blue	Brown, Gray, Black, Blue, Black
above 5 Cores	Yellow/Green, Black Numbered	Black Numbered

Sheath Colour: Black (other colors upon request)

PHYSICAL AND THERMAL PROPERTIES

Temperature range during operation (fixed state): -30°C – +90°C

Temperature range during installation (mobile state): -20°C – +50°C

Minimum bending radius: 6 x Overall Diameter

ELECTRICAL PROPERTIES

Dielectric test:	450/750V: 2500 V r.m.s. x 5' (core/core)
Insulation resistance	20 MΩ x km (at 20°C)
Short circuit temperature	250°C

CONSTRUCTION PARAMETERS

Conductor		FFX100 07mZ1-R		
Nominal Cross Section Area	No./Nominal Diameter of Strands	Nominal Insulation Thickness	Nominal Overall Diameter	Approx. Weight
mm ²	No./mm	mm	mm	kg/km
1.5	7/0.53	0.7	3.5	25
2.5	7/0.67	0.8	4.1	35
4	7/0.85	0.8	4.6	52
6	7/1.04	0.8	5.2	72
10	7/1.35	1	6.5	120



Conductor		FFX100 07mZ1-R		
Nominal Cross Section Area	No./Nominal Diameter of Strands	Nominal Insulation Thickness	Nominal Overall Diameter	Approx. Weight
mm ²	No./mm	mm	mm	kg/km
16	7/1.70	1	7.6	180
25	7/2.14	1.2	9	275
35	7/2.52	1.2	10.2	370
50	19/2.52	1.4	11.8	500
70	19/2.14	1.4	13.4	700
95	19.2.52	1.6	15.8	980
150	37/2.52	1.8	18.8	1500
185	37/2.52	2	21	1900
240	37/2.52	2.2	25.7	2500
300	37/2.52	2.4	28.6	3140
400	61/2.85	2.6	32	4000
500	61/3.20	2.8	35.5	5000
630	127/2.52	2.8	39.5	6300

ELECTRICAL PROPERTIES

Conductor Operating Temperature : 90°C

Ambient Temperature : 30°C

Current-Carrying Capacities (Amp)

Conductor cross-section area	Reference Method 4 (enclosed in conduit in thermally insulating wall etc)		Reference Method 3 (enclosed in conduit on a wall or in trunking etc)		Reference Method 1 (clipped direct)		Reference Method 11 (on a perforated cable tray, horizontal or vertical)		Reference Method 12 (free air)		
									Horizontal flat spaced	Vertical flat spaced	Trefoil
	2 cables, single-phase a.c. or d.c.	3 or 4 cables, 3-phase a.c.	2 cables, single-phase a.c. or d.c.	3 or 4 cables, 3-phase a.c.	2 cables, single-phase a.c. or d.c. flat and touching	3 or 4 cables, 3-phase a.c. flat and touching or trefoil	2 cables, single-phase a.c. or d.c. or flat and touching	3 or 4 cables, 3-phase a.c. flat and touching or trefoil	2 cables, single-phase a.c. or d.c. or 3 cables three phase	2 cables, single-phase a.c. or d.c. or 3 cables three phase	3 cables, trefoil 3-phase a.c.
1	2	3	4	5	6	7	8	9	10	11	12
mm ²	A	A	A	A	A	A	A	A	A	A	A
1.5	18	17	22	19	25	23	-	-	-	-	-
2.5	24	23	30	26	34	31	-	-	-	-	-

4	33	30	40	35	46	41	-	-	-	-	-
6	43	39	51	45	59	54	-	-	-	-	-
10	58	53	71	63	81	74	-	-	-	-	-
16	76	70	95	85	109	99	-	-	-	-	-
25	100	91	126	111	143	130	158	140	183	163	138
35	125	111	156	138	176	161	195	176	226	203	171
50	149	135	189	168	228	209	293	215	274	246	209
70	189	170	240	214	293	268	308	279	351	318	270
95	228	205	290	259	355	326	375	341	426	389	330
120	263	235	336	299	413	379	436	398	495	453	385
150	300	270	375	328	476	436	505	461	570	524	445
185	341	306	426	370	545	500	579	530	651	600	511
240	400	358	500	433	644	590	686	630	769	711	606
300	459	410	573	493	743	681	794	730	886	824	701
400	-	-	684	584	868	793	915	849	1065	994	820
500	-	-	783	666	990	904	1044	973	1228	1150	936
630	-	-	900	764	1130	1033	1191	1115	1423	1338	1069

Voltage Drop (Per Amp Per Meter)

Nominal Cross Section Area	2 cables d.c.	2 cables, single-phase a.c.						3 or 4 cables, 3-phase a.c.								
		Ref. Methods 3 and 4 (enclosed in conduit etc, in or on a wall)			Ref. Methods 1 and 11 (clipped direct or on trays touching)			Ref. Methods 3 and 4 (enclosed in conduit etc, in or on a wall)			Ref. Methods 1, 11 and 12 (in trefoil)			Ref. Methods 1 and 11 (Flat and touching)		
1	2	3			4			5			6			7		
mm ²	mV/A/m	mV/A/m			mV/A/m			mV/A/m			mV/A/m			mV/A/m		
1.5	31		31			27			27			27			27	
2.5	19		19			16			16			16			16	
4	33		12			10			10			10			10	
6	7.8		7.9			6.8			6.8			6.8			6.8	
10	4.7		4.7			4.7			4			4			4	
16	2.9		2.9			2.9			2.5			2.5			2.5	
		r	x	z	r	x	z	r	x	z	r	x	z	r	x	z
25	1.85	1.6	0.31	1.9	1.85	0.19	1.85	1.6	0.27	1.65	1.6	0.165	1.6	1.6	0.19	1.6
35	1.35	1.35	0.29	1.35	1.35	0.18	1.35	1.15	0.25	1.15	1.15	0.155	1.5	1.15	0.18	1.15
50	0.99	1	0.29	1.05	0.99	0.18	1	0.87	0.25	0.9	0.86	0.155	0.87	0.86	0.18	0.87
70	0.68	0.7	0.28	0.75	0.68	0.175	0.71	0.6	0.24	0.65	0.59	0.15	0.61	0.59	0.175	0.62
95	0.49	0.51	0.27	0.58	0.49	0.17	0.52	0.44	0.23	0.5	0.43	0.145	0.45	0.43	0.17	0.46



Caledonian

Fire Resistant Power & Control Cables

www.caledonian-cables.co.uk www.addison-cables.com



120	0.39	0.41	0.26	0.48	0.39	0.165	0.43	0.35	0.23	0.42	0.34	0.14	0.37	0.34	0.165	0.38
150	0.32	0.33	0.26	0.43	0.32	0.165	0.36	0.29	0.23	0.37	0.28	0.14	0.31	0.28	0.165	0.32
185	0.25	0.27	0.26	0.37	0.26	0.165	0.3	0.23	0.23	0.32	0.22	0.14	0.26	0.22	0.165	0.28
240	0.19	0.21	0.26	0.33	0.2	0.16	0.25	0.185	0.22	0.29	0.17	0.14	0.22	0.17	0.165	0.24
300	0.155	0.175	0.25	0.31	0.16	0.16	0.22	0.15	0.22	0.27	0.14	0.14	0.195	0.135	0.16	0.21
400	0.12	0.14	0.25	0.29	0.13	0.155	0.2	0.125	0.22	0.25	0.11	0.135	0.175	0.11	0.16	0.195
500	0.093	0.12	0.25	0.28	0.105	0.155	0.185	0.1	0.22	0.24	0.09	0.135	0.16	0.088	0.16	0.18
630	0.072	0.1	0.25	0.27	0.086	0.155	0.175	0.088	0.21	0.23	0.074	0.135	0.15	0.071	0.16	0.17

Note : r = conductor resistance at operating temperature
 x = reactance
 z = impedance

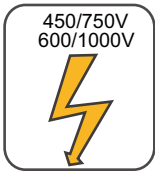

Rated Voltage



Standard

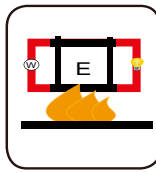

Circuit Integrity
 IEC 60331/BS 6387
 NF C32-070-2.3(CR1)



Reduced Fire Propagation
 NF C32-070-2.2(C1)
 IEC60332-3-24
 EN50266-2-4



Flame Retardancy
 NF C32-070-2.1(C2)
 IEC60332-1-2/EN50265-2-1



Low Toxicity
 NES 02-713/NF C 20-454



Low Corrosivity
 IEC60754-2
 EN50267-2-2/3
 NF C 32-074



Low Smoke Emission
 IEC 61034-1&2
 EN 50268-1&2/NF C32-073

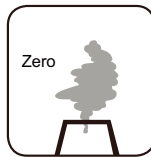

Halogen Free
 IEC60754-1/
 EN50267-2-1

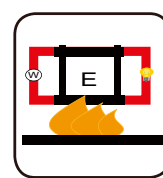

Functional Integrity
 DIN 4102-12

600/1000V Mica+LSZH Insulated Power Cables (Single Core)

FFX100 1mZ1-R (CU/MGT+LSZH 600/1000V Class 2)

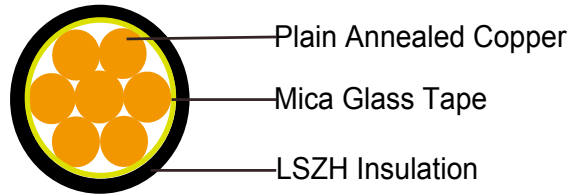
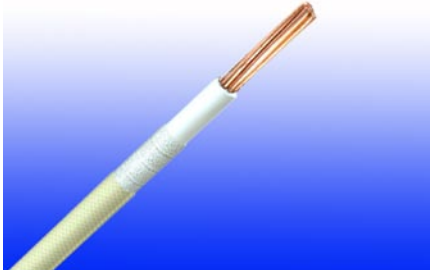

APPLICATION

This cable is used in fire extinguishing systems, sprinklers, control panels, and exit lights in high-rise buildings, hotels, hospitals, sub-ways, and public facilities.

STANDARDS

Basic design to BS 7211

FIRE PERFORMANCE

Circuit Integrity	IEC 60331-21; BS 6387 CWZ; DIN VDE 0472-814(FE180); CEI 20-36/2-1; SS299-1; NBN C 30-004 (cat. F3); NF C32-070-2.3(CR1)
System Circuit Integrity	DIN 4102-12, E30 depending on lay system
Flame Retardance (Single Vertical Wire Test)	EN 60332-1-2; IEC 60332-1-2; BS EN 60332-1-2; VDE 0482-332-1 ; NBN C 30-004 (cat. F1); NF C32-070-2.1(C2); CEI 20-35/1-2; EN 50265-2-1*; DIN VDE 0482-265-2-1*
Reduced Fire Propagation (Vertically-mounted bundled wires & cable test)	EN 60332-3-24 (cat. C); IEC 60332-3-24; BS EN 60332-3-24; VDE 0482-332-3; NBN C 30-004 (cat. F2); NF C32-070-2.2(C1); CEI 20-22/3-4; EN 50266-2-4*; DIN VDE 0482-266-2-4
Halogen Free	IEC 60754-1; EN 50267-2-1; DIN VDE 0482-267-2-1; CEI 20-37/2-1 ; BS 6425-1*
No Corrosive Gas Emission	IEC 60754-2; EN 50267-2-2; DIN VDE 0482-267-2-2; CEI 20-37/2-2 ; BS 6425-2*
Minimum Smoke Emission	IEC 61034-1&2; EN 61034 -1&2; DIN VDE 0482-1034-1&2; CEI 20-37/3-1&2; EN 50268-1&2*; BS 7622-1&2*
No Toxic gases	NES 02-713; NF C 20-454

Note: Asterisk * denotes superseded standard.

VOLTAGE RATING

600/1000V



CABLE CONSTRUCTION

Conductor: Plain annealed copper wire, stranded according to IEC 60228 class 2

Fire Barrier: Mica glass tape

Insulation: Thermoplastic LSZH compound type LTS3 as per BS 7655-6.1 (Thermosetting LSZH compound type SW2-SW4 as per BS 7655-2.6 can be offered.). UV resistance, hydrocarbon resistance, oil resistance, anti rodent and anti termite properties can be offered as option.

COLOUR CODE

Insulation Colour as per BS7671

	With Earth Conductor	Without Earth Conductor
2Cores	-	Brown, Blue
3Cores	Yellow/Green, Brown, Blue	Brown, Gray, Black
4Cores	Yellow/Green, Brown, Gray, Black	Brown, Gray, Black, Blue
5Cores	Yellow/Green, Brown, Gray, Black, Blue	Brown, Gray, Black, Blue, Black
above 5 Cores	Yellow/Green, Black Numbered	Black Numbered

Sheath Colour: Black (other colors upon request)

PHYSICAL AND THERMAL PROPERTIES

Temperature range during operation (fixed state): -30°C – +90°C

Temperature range during installation (mobile state): -20°C – +50°C

Minimum bending radius: 6 x Overall Diameter

ELECTRICAL PROPERTIES

Dielectric test:	600/1000V: 3500 V r.m.s. x 5' (core/core);
Insulation resistance	20 MΩ x km (at 20°C)
Short circuit temperature	250°C

CONSTRUCTION PARAMETERS

Conductor		FFX100 1mZ1-R		
Nominal Cross Section Area	No./Nominal Diameter of Strands	Nominal Insulation Thickness	Nominal Overall Diameter	Approx. Weight
mm ²	No./mm	mm	mm	kg/km
1.5	7/0.53	0.8	3.8	30
2.5	7/0.67	0.8	4.2	40
4	7/0.85	1	5.3	70
6	7/1.04	1	6	96
10	7/1.35	1	6.6	130

Conductor		FFX100 1mZ1-R		
Nominal Cross Section Area	No./Nominal Diameter of Strands	Nominal Insulation Thickness	Nominal Overall Diameter	Approx. Weight
mm ²	No./mm	mm	mm	kg/km
16	7/1.70	1	7.7	200
25	7/2.14	1.2	9.1	290
35	7/2.52	1.2	10.3	390
50	19/2.52	1.4	11.9	520
70	19/2.14	1.4	13.5	730
95	19.2.52	1.6	15.9	990
150	37/2.52	1.8	18.9	1520
185	37/2.52	2	21.2	1900
240	37/2.52	2.2	25.8	2550
300	37/2.52	2.4	28.8	3150
400	61/2.85	2.6	32.2	4000
500	61/3.20	2.8	35.7	5000
630	127/2.52	2.8	39.7	6360

ELECTRICAL PROPERTIES

Conductor Operating Temperature : 90°C

Ambient Temperature : 30°C

Current-Carrying Capacities (Amp)

Conductor cross-section area	Reference Method 4 (enclosed in conduit in thermally insulating wall etc)		Reference Method 3 (enclosed in conduit on a wall or in trunking etc)		Reference Method 1 (clipped direct)		Reference Method 11 (on a perforated cable tray, horizontal or vertical)		Reference Method 12 (free air)		
	2 cables, single-phase a.c. or d.c.	3 or 4 cables, 3-phase a.c.	2 cables, single-phase a.c. or d.c.	3 or 4 cables, 3-phase a.c.	2 cables, single-phase a.c. or d.c. flat and touching	3 or 4 cables, 3-phase a.c. flat and touching or trefoil	2 cables, single-phase a.c. or d.c. or flat and touching	3 or 4 cables, 3-phase a.c. flat and touching or trefoil	Horizontal flat spaced	Vertical flat spaced	Trefoil
1	2	3	4	5	6	7	8	9	10	11	12
mm ²	A	A	A	A	A	A	A	A	A	A	A
1.5	18	17	22	19	25	23	-	-	-	-	-
2.5	24	23	30	26	34	31	-	-	-	-	-
4	33	30	40	35	46	41	-	-	-	-	-



6	43	39	51	45	59	54	-	-	-	-	-
10	58	53	71	63	81	74	-	-	-	-	-
16	76	70	95	85	109	99	-	-	-	-	-
25	100	91	126	111	143	130	158	140	183	163	138
35	125	111	156	138	176	161	195	176	226	203	171
50	149	135	189	168	228	209	293	215	274	246	209
70	189	170	240	214	293	268	308	279	351	318	270
95	228	205	290	259	355	326	375	341	426	389	330
120	263	235	336	299	413	379	436	398	495	453	385
150	300	270	375	328	476	436	505	461	570	524	445
185	341	306	426	370	545	500	579	530	651	600	511
240	400	358	500	433	644	590	686	630	769	711	606
300	459	410	573	493	743	681	794	730	886	824	701
400	-	-	684	584	868	793	915	849	1065	994	820
500	-	-	783	666	990	904	1044	973	1228	1150	936
630	-	-	900	764	1130	1033	1191	1115	1423	1338	1069

Voltage Drop (Per Amp Per Meter)

Nominal Cross Section Area	2 cables d.c.	2 cables, single-phase a.c.						3 or 4 cables, 3-phase a.c.								
		Ref. Methods 3 and 4 (enclosed in conduit etc, in or on a wall)			Ref. Methods 1 and 11 (clipped direct or on trays touching)			Ref. Methods 3 and 4 (enclosed in conduit etc, in or on a wall)			Ref. Methods 1, 11 and 12 (in trefoil)			Ref. Methods 1 and 11 (Flat and touching)		
1	2	3			4			5			6			7		
mm ²	mV/A/m	mV/A/m			mV/A/m			mV/A/m			mV/A/m			mV/A/m		
1.5	31		31			27			27			27			27	
2.5	19		19			16			16			16			16	
4	33		12			10			10			10			10	
6	7.8		7.9			6.8			6.8			6.8			6.8	
10	4.7		4.7			4.7			4			4			4	
16	2.9		2.9			2.9			2.5			2.5			2.5	
		r	x	z	r	x	z	r	x	z	r	x	z	r	x	z
25	1.85	1.6	0.31	1.9	1.85	0.19	1.85	1.6	0.27	1.65	1.6	0.165	1.6	1.6	0.19	1.6
35	1.35	1.35	0.29	1.35	1.35	0.18	1.35	1.15	0.25	1.15	1.15	0.155	1.5	1.15	0.18	1.15
50	0.99	1	0.29	1.05	0.99	0.18	1	0.87	0.25	0.9	0.86	0.155	0.87	0.86	0.18	0.87
70	0.68	0.7	0.28	0.75	0.68	0.175	0.71	0.6	0.24	0.65	0.59	0.15	0.61	0.59	0.175	0.62
95	0.49	0.51	0.27	0.58	0.49	0.17	0.52	0.44	0.23	0.5	0.43	0.145	0.45	0.43	0.17	0.46
120	0.39	0.41	0.26	0.48	0.39	0.165	0.43	0.35	0.23	0.42	0.34	0.14	0.37	0.34	0.165	0.38

150	0.32	0.33	0.26	0.43	0.32	0.165	0.36	0.29	0.23	0.37	0.28	0.14	0.31	0.28	0.165	0.32
185	0.25	0.27	0.26	0.37	0.26	0.165	0.3	0.23	0.23	0.32	0.22	0.14	0.26	0.22	0.165	0.28
240	0.19	0.21	0.26	0.33	0.2	0.16	0.25	0.185	0.22	0.29	0.17	0.14	0.22	0.17	0.165	0.24
300	0.155	0.175	0.25	0.31	0.16	0.16	0.22	0.15	0.22	0.27	0.14	0.14	0.195	0.135	0.16	0.21
400	0.12	0.14	0.25	0.29	0.13	0.155	0.2	0.125	0.22	0.25	0.11	0.135	0.175	0.11	0.16	0.195
500	0.093	0.12	0.25	0.28	0.105	0.155	0.185	0.1	0.22	0.24	0.09	0.135	0.16	0.088	0.16	0.18
630	0.072	0.1	0.25	0.27	0.086	0.155	0.175	0.088	0.21	0.23	0.074	0.135	0.15	0.071	0.16	0.17

Note : r = conductor resistance at operating temperature

x = reactance

z = impedance

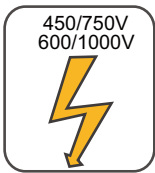

Rated Voltage



Standard

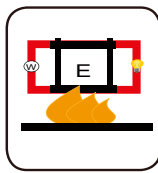

Circuit Integrity
IEC 60331/BS 6387
NF C32-070-2.3(CR1)



Reduced Fire Propagation
NF C32-070-2.2(C1)
IEC60332-3-24
EN50266-2-4



Flame Retardancy
NF C32-070-2.1(C2)
IEC60332-1-2/EN50265-2-1



Low Toxicity
NES 02-713/NF C 20-454



Low Corrosivity
IEC60754-2
EN50267-2-2/3
NF C 32-074



Low Smoke Emission
IEC 61034-1&2
EN 50268-1&2/NF C32-073

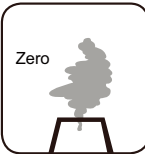

Halogen Free
IEC60754-1/
EN50267-2-1

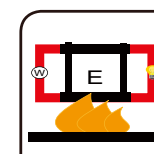

Functional Integrity
DIN 4102-12



300/500V Mica+XLPE Insulated, LSZH Sheathed Power Cables (Single Core)

FFX300 05mRZ1-R (CU/MGT+XLPE/LSZH 300/500V Class 2)

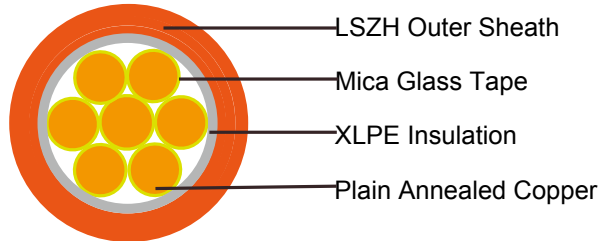
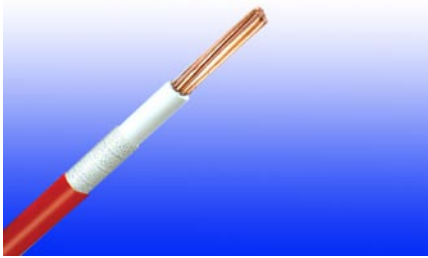

APPLICATION

The cables are designed for areas where the integrity of the electrical circuit is critical in maintaining power supply. Applications can be found in emergency lightings, control and power circuits, power stations, fire alarm systems, underground tunnels, lifts, escalators, and high-rise buildings.

STANDARDS

Basic design to IEC 60502-1

FIRE PERFORMANCE

Circuit Integrity	IEC 60331-21; BS 6387 CWZ; DIN VDE 0472-814(FE180); CEI 20-36/2-1; SS299-1; NBN C 30-004 (cat. F3); NF C32-070-2.3(CR1)
System Circuit Integrity	DIN 4102-12, E30 depending on lay system
Flame Retardance (Single Vertical Wire Test)	EN 60332-1-2; IEC 60332-1-2; BS EN 60332-1-2; VDE 0482-332-1 ; NBN C 30-004 (cat. F1); NF C32-070-2.1(C2); CEI 20-35/1-2; EN 50265-2-1*; DIN VDE 0482-265-2-1*
Reduced Fire Propagation (Vertically-mounted bundled wires & cable test)	EN 60332-3-24 (cat. C); IEC 60332-3-24; BS EN 60332-3-24; VDE 0482-332-3; NBN C 30-004 (cat. F2); NF C32-070-2.2(C1); CEI 20-22/3-4; EN 50266-2-4*; DIN VDE 0482-266-2-4
Halogen Free	IEC 60754-1; EN 50267-2-1; DIN VDE 0482-267-2-1; CEI 20-37/2-1 ; BS 6425-1*
No Corrosive Gas Emission	IEC 60754-2; EN 50267-2-2; DIN VDE 0482-267-2-2; CEI 20-37/2-2 ; BS 6425-2*
Minimum Smoke Emission	IEC 61034-1&2; EN 61034 -1&2; DIN VDE 0482-1034-1&2; CEI 20-37/3-1&2; EN 50268-1&2*; BS 7622-1&2*
No Toxic gases	NES 02-713; NF C 20-454

Note: Asterisk * denotes superseded standard.

VOLTAGE RATING

300/500 V

CABLE CONSTRUCTION

Conductor: Plain annealed copper wire, stranded according to IEC 60228 class 2.

Insulation: Mica glass tape covered by extruded cross-linked XLPE compound

Earth Conductor(optional): Uninsulated solid or stranded tinned copper conductor.

Outer Sheath: Thermoplastic LSZH compound type LTS3 as per BS 7655-6.1 (Thermosetting LSZH compound type SW2-SW4 as per BS 7655-2.6 can be offered.). UV resistance, hydrocarbon resistance, oil resistance, anti rodent and anti termite properties can be offered as option.

COLOUR CODE

Insulation Colour as per BS7671

	With Earth Conductor	Without Earth Conductor
2Cores	-	Brown, Blue
3Cores	Yellow/Green, Brown, Blue	Brown, Gray, Black
4Cores	Yellow/Green, Brown, Gray, Black	Brown, Gray, Black, Blue
5Cores	Yellow/Green, Brown, Gray, Black, Blue	Brown, Gray, Black, Blue, Black
above 5 Cores	Yellow/Green, Black Numbered	Black Numbered

Sheath Colour: Black (other colors upon request)

PHYSICAL AND THERMAL PROPERTIES

Temperature range during operation (fixed state): -30°C – +90°C

Temperature range during installation (mobile state): -20°C – +50°C

Minimum bending radius: 8 x Overall Diameter

ELECTRICAL PROPERTIES

Dielectric test:	2000 V r.m.s. x 5' (core/core)
Insulation resistance	1000 MΩ x km (at 20°C)
Short circuit temperature	250°C

CONSTRUCTION PARAMETERS

Conductor		FFX300 05mRZ1-R			
Nominal Cross Section Area	No./Nominal Diameter of Strands	Nominal Insulation Thickness	Nominal Sheath Thickness	Without Earth Conductor	
				Nominal Overall Diameter	Approx. Weight
mm ²	No./mm	mm	mm	mm	kg/km
1.5	7/0.53	0.5	0.5	4.4	29
2.5	7/0.67	0.5	0.5	4.9	40
4	7/0.85	0.5	0.5	5.5	55



ELECTRICAL PROPERTIES

Conductor Operating Temperature : 90°C

Ambient Temperature : 30°C

Current-Carrying Capacities (Amp)

Conductor cross-section area	Reference Method 4 (enclosed in conduit in thermally insulating wall etc)		Reference Method 3 (enclosed in conduit on a wall or in trunking etc)		Reference Method 1 (clipped direct)		Reference Method 11 (on a perforated cable tray, horizontal or vertical)		Reference Method 12 (free air)		
	2 cables, single-phase a.c. or d.c.	3 or 4 cables, 3-phase a.c.	2 cables, single-phase a.c. or d.c.	3 or 4 cables, 3-phase a.c.	2 cables, single-phase a.c. or d.c. flat and touching	3 or 4 cables, 3-phase a.c. flat and touching or trefoil	2 cables, single-phase a.c. or d.c. or flat and touching	3 or 4 cables, 3-phase a.c. flat and touching or trefoil	Horizontal flat spaced	Vertical flat spaced	Trefoil
1	2	3	4	5	6	7	8	9	10	11	12
mm ²	A	A	A	A	A	A	A	A	A	A	A
1.5	18	17	22	19	25	23	-	-	-	-	-
2.5	24	23	30	26	34	31	-	-	-	-	-
4	33	30	40	35	46	41	-	-	-	-	-

Voltage Drop (Per Amp Per Meter)

Nominal Cross Section Area	2 cables d.c.	2 cables, single-phase a.c.		3 or 4 cables, 3-phase a.c.		
		Ref. Methods 3 and 4 (enclosed in conduit etc, in or on a wall)	Ref. Methods 1 and 11 (clipped direct or on trays touching)	Ref. Methods 3 and 4 (enclosed in conduit etc, in or on a wall)	Ref. Methods 1, 11 and 12 (in trefoil)	Ref. Methods 1 and 11 (Flat and touching)
1	2	3	4	5	6	7
mm ²	mV/A/m	mV/A/m	mV/A/m	mV/A/m	mV/A/m	mV/A/m
1.5	31	31	27	27	27	27
2.5	19	19	16	16	16	16
4	33	12	10	10	10	10



300/500V

Rated Voltage



IEC 60502-1

Standard

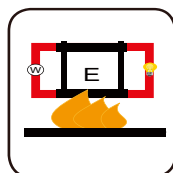

Circuit Integrity
IEC 60331/BS 6387
NF C32-070-2.3(CR1)



Reduced Fire Propagation
NF C32-070-2.2(C1)
IEC60332-3-24/EN50266-2-4



Flame Retardancy
NF C32-070-2.1(C2)
IEC60332-1-2/EN50265-2-1



Low Toxicity
NES 02-713/NF C 20-454



Low Corrosivity
IEC60754-2
EN50267-2-2/3
NF C 32-074



Low Smoke Emission
IEC 61034-1&2
EN 50268-1&2/NF C32-073



Zero
Halogen Free
IEC60754-1
EN50267-2-1

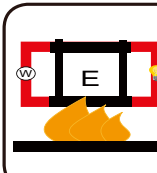

Functional Integrity
DIN 4102-12

600/1000V Mica+XLPE Insulated, LSZH Sheathed Power Cables (Single-Core)

FFX300 1mRZ1-R (CU/MGT+XLPE/LSZH 600/1000V Class 2)

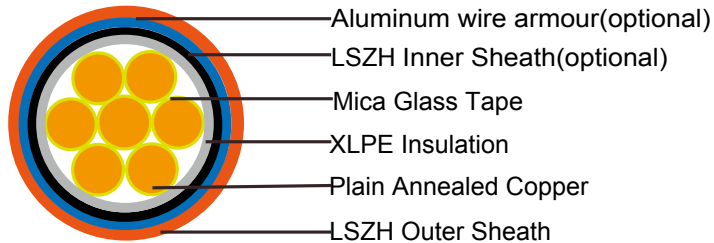
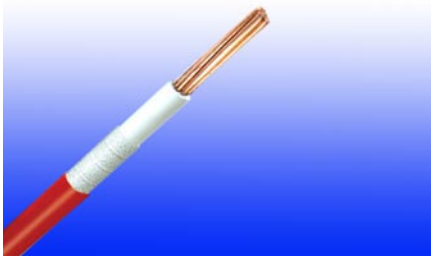

APPLICATION

This cable is designed for areas where the integrity of the electrical circuit is critical in maintaining power supply. Applications can be found in emergency lightings, control and power circuits, power stations, fire alarm systems, underground tunnels, communications systems, sewage treatment plants, lifts, escalators, and high-rise buildings.

STANDARDS

Basic design to IEC 60502-1 / BS 6724

FIRE PERFORMANCE

Circuit Integrity	IEC 60331-21; BS 6387 CWZ; DIN VDE 0472-814(FE180); CEI 20-36/2-1; SS299-1; NBN C 30-004 (cat. F3); NF C32-070-2.3(CR1)
System Circuit Integrity	DIN 4102-12, E30 depending on lay system
Flame Retardance (Single Vertical Wire Test)	EN 60332-1-2; IEC 60332-1-2; BS EN 60332-1-2; VDE 0482-332-1 ; NBN C 30-004 (cat. F1); NF C32-070-2.1(C2); CEI 20-35/1-2; EN 50265-2-1*; DIN VDE 0482-265-2-1*
Reduced Fire Propagation (Vertically-mounted bundled wires & cable test)	EN 60332-3-24 (cat. C); IEC 60332-3-24; BS EN 60332-3-24; VDE 0482-332-3; NBN C 30-004 (cat. F2); NF C32-070-2.2(C1); CEI 20-22/3-4; EN 50266-2-4*; DIN VDE 0482-266-2-4
Halogen Free	IEC 60754-1; EN 50267-2-1; DIN VDE 0482-267-2-1; CEI 20-37/2-1 ; BS 6425-1*
No Corrosive Gas Emission	IEC 60754-2; EN 50267-2-2; DIN VDE 0482-267-2-2; CEI 20-37/2-2 ; BS 6425-2*
Minimum Smoke Emission	IEC 61034-1&2; EN 61034 -1&2; DIN VDE 0482-1034-1&2; CEI 20-37/3-1&2; EN 50268-1&2*; BS 7622-1&2*
No Toxic gases	NES 02-713; NF C 20-454

Note: Asterisk * denotes superseded standard.



VOLTAGE RATING

600/1000 V

CABLE CONSTRUCTION

Conductor: Plain annealed copper wire, stranded according to IEC 60228 class 2.

Insulation: Mica glass tape covered by extruded cross-linked XLPE compound

Outer Sheath: Thermoplastic LSZH compound type LTS3 as per BS 7655-6.1 (Thermosetting LSZH compound type SW2-SW4 as per BS 7655-2.6 can be offered.). UV resistance, hydrocarbon resistance, oil resistance, anti rodent and anti termite properties can be offered as option.

COLOUR CODE

Insulation Colour: Natural (other colors upon request)

Sheath Colour: Black (other colors upon request)

PHYSICAL AND THERMAL PROPERTIES

Temperature range during operation (fixed state): -30°C – +90°C

Temperature range during installation (mobile state): -20°C – +50°C

Minimum bending radius: 8 x Overall Diameter (unarmoured cable)
10 x Overall Diameter (armoured cable)

ELECTRICAL PROPERTIES

Dielectric test:	3500 V r.m.s. x 5' (core/core)
Insulation resistance	1000 MΩ x km (at 20°C)
Short circuit temperature	250°C

CONSTRUCTION PARAMETERS

Conductor				FFX300 1mRZ1-R	
Nominal Cross Section Area	No./Nominal Diameter of Strands	Dia. of Conductor	Nominal Insulation Thickness	Approx. Overall Diameter	Approx. Weight
mm ²	No./mm	mm	mm	mm	kg/km
1.5	7/0.53	1.59	0.7	6.5	54
2.5	7/0.67	2.01	0.7	6.8	67
4	7/0.85	2.55	0.7	7.5	86
6	7/1.04	3.12	0.7	8.1	110
10	7/1.35	4.05	0.7	9.2	155
16	7/1.70	5.1	0.7	10.2	220
25	7/2.14	6.42	0.9	11.9	325
35	19/1.53	7.65	0.9	13.2	425
50	19/1.78	8.9	1	14.6	600
70	19/2.14	10.7	1.1	16.6	820
95	19/2.52	12.6	1.1	18.7	1100

Conductor				FFX300 1mRZ1-R	
Nominal Cross Section Area	No./Nominal Diameter of Strands	Dia. of Conductor	Nominal Insulation Thickness	Approx. Overall Diameter	Approx. Weight
mm ²	No./mm	mm	mm	mm	kg/km
120	37/2.03	14.21	1.2	20.5	1350
150	37/2.25	15.75	1.4	22.7	1640
185	37/2.52	17.64	1.6	25.5	2040
240	61/2.25	20.25	1.7	28.5	2650
300	61/2.52	22.68	1.8	31.5	3260
400	65/2.85	25.65	2	35.4	4130
500	61/3.20	28.8	2.2	39	5200
630	127/2.52	32.76	2.4	43.5	6600
800	127/2.85	37.05	2.6	48.5	8300
1000	127/3.20	41.6	2.8	53.5	10000

ELECTRICAL PROPERTIES

Conductor Operating Temperature : 90°C

Ambient Temperature : 30°C

Current-Carrying Capacities (Amp)

Conductor cross-section area	Reference Method 4 (enclosed in conduit in thermally insulating wall etc)		Reference Method 3 (enclosed in conduit on a wall or in trunking etc)		Reference Method 1 (clipped direct)		Reference Method 11 (on a perforated cable tray, horizontal or vertical)		Reference Method 12 (free air)		
	2 cables, single-phase a.c. or d.c.	3 or 4 cables, 3-phase a.c.	2 cables, single-phase a.c. or d.c.	3 or 4 cables, 3-phase a.c.	2 cables, single-phase a.c. or d.c. flat and touching	3 or 4 cables, 3-phase a.c. flat and touching or trefoil	2 cables, single-phase a.c. or d.c. or flat and touching	3 or 4 cables, 3-phase a.c. flat and touching or trefoil	Horizontal flat spaced	Vertical flat spaced	Trefoil
mm ²	A	A	A	A	A	A	A	A	A	A	A
1.5	18	17	22	19	25	23	-	-	-	-	-
2.5	24	23	30	26	34	31	-	-	-	-	-
4	33	30	40	35	46	41	-	-	-	-	-
6	43	39	51	45	59	54	-	-	-	-	-
10	58	53	71	63	81	74	-	-	-	-	-
16	76	70	95	85	109	99	-	-	-	-	-
25	100	91	126	111	143	130	158	140	183	163	138
35	125	111	156	138	176	161	195	176	226	203	171



50	149	135	189	168	228	209	293	215	274	246	209
70	189	170	240	214	293	268	308	279	351	318	270
95	228	205	290	259	355	326	375	341	426	389	330
120	263	235	336	299	413	379	436	398	495	453	385
150	300	270	375	328	476	436	505	461	570	524	445
185	341	306	426	370	545	500	579	530	651	600	511
240	400	358	500	433	644	590	686	630	769	711	606
300	459	410	573	493	743	681	794	730	886	824	701
400	-	-	684	584	868	793	915	849	1065	994	820
500	-	-	783	666	990	904	1044	973	1228	1150	936
630	-	-	900	764	1130	1033	1191	1115	1423	1338	1069
800	-	-	-	-	1288	1179	1358	1275	1580	1485	1214
1000	-	-	-	-	1443	1323	1520	1436	1775	1671	1349

Voltage Drop (Per Amp Per Meter)

Nominal Cross Section Area	2 cables d.c.	2 cables, single-phase a.c.						3 or 4 cables, 3-phase a.c.								
		Ref. Methods 3 and 4 (enclosed in conduit etc, in or on a wall)			Ref. Methods 1 and 11 (clipped direct or on trays touching)			Ref. Methods 3 and 4 (enclosed in conduit etc, in or on a wall)			Ref. Methods 1, 11 and 12 (in trefoil)			Ref. Methods 1 and 11 (Flat and touching)		
		1	2	3	4	5	6	7	8	9	10	11	12	13	14	15
mm ²	mV/A/m	mV/A/m			mV/A/m			mV/A/m			mV/A/m			mV/A/m		
1.5	31	31			27			27			27			27		
2.5	19	19			16			16			16			16		
4	33	12			10			10			10			10		
6	7.8	7.9			6.8			6.8			6.8			6.8		
10	4.7	4.7			4.7			4			4			4		
16	2.9	2.9			2.9			2.5			2.5			2.5		
		r	x	z	r	x	z	r	x	z	r	x	z	r	x	z
25	1.85	1.85	0.31	1.9	1.85	0.19	1.85	1.6	0.27	1.65	1.6	0.165	1.6	1.6	0.19	1.6
35	1.35	1.35	0.29	1.35	1.35	0.18	1.35	1.15	0.25	1.15	1.15	0.155	1.5	1.15	0.18	1.15
50	0.99	1	0.29	1.05	0.99	0.18	1	0.87	0.25	0.9	0.86	0.155	0.87	0.86	0.18	0.87
70	0.68	0.7	0.28	0.75	0.68	0.175	0.71	0.6	0.24	0.65	0.59	0.15	0.61	0.59	0.175	0.62
95	0.49	0.51	0.27	0.58	0.49	0.17	0.52	0.44	0.23	0.5	0.43	0.145	0.45	0.43	0.17	0.46
120	0.39	0.41	0.26	0.48	0.39	0.165	0.43	0.35	0.23	0.42	0.34	0.14	0.37	0.34	0.165	0.38
150	0.32	0.33	0.26	0.43	0.32	0.165	0.36	0.29	0.23	0.37	0.28	0.14	0.31	0.28	0.165	0.32
185	0.25	0.27	0.26	0.37	0.26	0.165	0.3	0.23	0.23	0.32	0.22	0.14	0.26	0.22	0.165	0.28
240	0.19	0.21	0.26	0.33	0.2	0.16	0.25	0.185	0.22	0.29	0.17	0.14	0.22	0.17	0.165	0.24

300	0.155	0.175	0.25	0.31	0.16	0.16	0.22	0.15	0.22	0.27	0.14	0.14	0.195	0.135	0.16	0.21
400	0.12	0.14	0.25	0.29	0.13	0.155	0.2	0.125	0.22	0.25	0.11	0.135	0.175	0.11	0.16	0.195
500	0.093	0.12	0.25	0.28	0.105	0.155	0.185	0.1	0.22	0.24	0.09	0.135	0.16	0.088	0.16	0.18
630	0.072	0.1	0.25	0.27	0.086	0.155	0.175	0.088	0.21	0.23	0.074	0.135	0.15	0.071	0.16	0.17
800	0.056	-	-	-	0.072	0.15	0.17	-	-	-	0.062	0.13	0.145	0.059	0.155	0.165
1000	0.045	-	-	-	0.063	0.15	0.165	-	-	-	0.055	0.13	0.14	0.05	0.155	0.165

Note: r = conductor resistance at operating temperature

x = reactance

z = impedance



600/1000V



BS 6724
IEC 60502-1

Standard

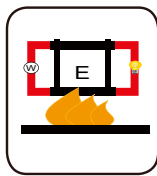

Circuit Integrity
IEC 60331/BS 6387
NF C32-070-2.3(CR1)



Reduced Fire Propagation
NF C32-070-2.2(C1)
IEC60332-3-24/EN50266-2-4



Flame Retardancy
NF C32-070-2.1(C2)
IEC60332-1-2/EN50265-2-1



Low Toxicity
NES 02-713/NF C 20-454



Low Corrosivity
IEC60754-2
EN50267-2-2/3
NF C 32-074



Low Smoke Emission
IEC 61034-1&2
EN 50268-1&2/NF C32-073

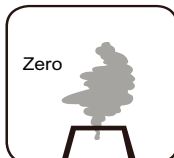

Zero

Halogen Free
IEC60754-1
EN50267-2-1

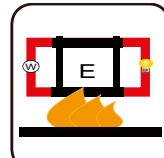

Functional Integrity
DIN 4102-12



600/1000V Mica+XLPE Insulated, Armoured LSZH Sheathed Power Cables (Single-Core)

FFX300 1mRMZ1-R (CU/MGT+XLPE/LSZH/AWA/LSZH 600/1000V Class 2)

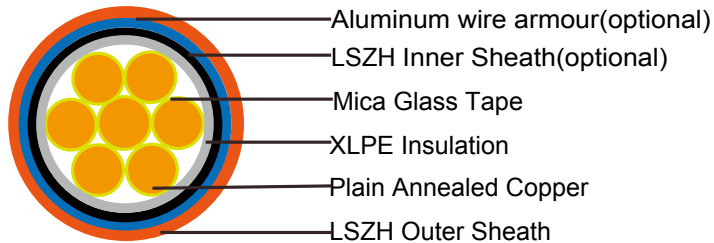
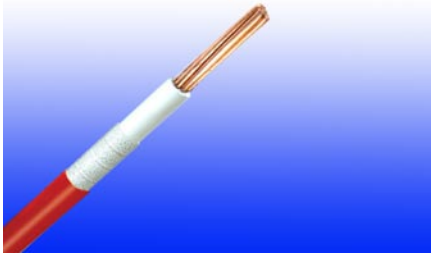

APPLICATION

This cable is designed for areas where the integrity of the electrical circuit is critical in maintaining power supply. Applications can be found in emergency lightings, control and power circuits, power stations, fire alarm systems, underground tunnels, communications systems, sewage treatment plants, lifts, escalators, and high-rise buildings.

STANDARDS

Basic design to IEC 60502-1 / BS 6724

FIRE PERFORMANCE

Circuit Integrity	IEC 60331-21; BS 6387 CWZ; DIN VDE 0472-814(FE180); CEI 20-36/2-1; SS299-1; NBN C 30-004 (cat. F3); NF C32-070-2.3(CR1)
System Circuit Integrity	DIN 4102-12, E30 depending on lay system
Flame Retardance (Single Vertical Wire Test)	EN 60332-1-2; IEC 60332-1-2; BS EN 60332-1-2; VDE 0482-332-1 ; NBN C 30-004 (cat. F1); NF C32-070-2.1(C2); CEI 20-35/1-2; EN 50265-2-1*; DIN VDE 0482-265-2-1*
Reduced Fire Propagation (Vertically-mounted bundled wires & cable test)	EN 60332-3-24 (cat. C); IEC 60332-3-24; BS EN 60332-3-24; VDE 0482-332-3; NBN C 30-004 (cat. F2); NF C32-070-2.2(C1); CEI 20-22/3-4; EN 50266-2-4*; DIN VDE 0482-266-2-4
Halogen Free	IEC 60754-1; EN 50267-2-1; DIN VDE 0482-267-2-1; CEI 20-37/2-1 ; BS 6425-1*
No Corrosive Gas Emission	IEC 60754-2; EN 50267-2-2; DIN VDE 0482-267-2-2; CEI 20-37/2-2 ; BS 6425-2*
Minimum Smoke Emission	IEC 61034-1&2; EN 61034 -1&2; DIN VDE 0482-1034-1&2; CEI 20-37/3-1&2; EN 50268-1&2*; BS 7622-1&2*
No Toxic gases	NES 02-713; NF C 20-454

Note: Asterisk * denotes superseded standard.

VOLTAGE RATING

600/1000 V

CABLE CONSTRUCTION

Conductor: Plain annealed copper wire, stranded according to IEC 60228 class 2.

Insulation: Mica glass tape covered by extruded cross-linked XLPE compound

Inner Sheath (optional): Thermoplastic LSZH compound type LTS3 as per BS 7655-6.1

Armouring (optional): Aluminum wire armour

Outer Sheath: Thermoplastic LSZH compound type LTS3 as per BS 7655-6.1 (Thermosetting LSZH compound type SW2-SW4 as per BS 7655-2.6 can be offered.). UV resistance, hydrocarbon resistance, oil resistance, anti rodent and anti termite properties can be offered as option.

COLOUR CODE

Insulation Colour: Natural (other colors upon request)

Sheath Colour: Black (other colors upon request)

PHYSICAL AND THERMAL PROPERTIES

Temperature range during operation (fixed state): -30°C – +90°C

Temperature range during installation (mobile state): -20°C – +50°C

Minimum bending radius: 8 x Overall Diameter (unarmoured cable)
10 x Overall Diameter (armoured cable)

ELECTRICAL PROPERTIES

Dielectric test:	3500 V r.m.s. x 5' (core/core)
Insulation resistance	1000 MΩ x km (at 20°C)
Short circuit temperature	250°C

CONSTRUCTION PARAMETERS

Conductor				FFX300 1mRMZ1-R	
Nominal Cross Section Area	No./Nominal Diameter of Strands	Dia. of Conductor	Nominal Insulation Thickness	Approx. Overall Diameter	Approx. Weight
mm ²	No./mm	mm	mm	mm	kg/km
50	19/1.78	8.9	1	18.5	780
70	19/2.14	10.7	1.1	20.5	1010
95	19/2.52	12.6	1.1	23	1320
120	37/2.03	14.21	1.2	24.5	1610
150	37/2.25	15.75	1.4	27	2010
185	37.2.52	17.64	1.6	29.5	2440
240	61/2.25	20.25	1.7	34.5	3060
300	61/2.52	22.68	1.8	36.9	3690
400	65/2.85	25.65	2	41.5	4780



500	61/3.20	28.8	2.2	45.5	5970
630	127/2.52	32.76	2.4	50.5	7530
800	127/2.85	37.05	2.6	56.8	9680
1000	127/3.20	41.6	2.8	61.5	11980

ELECTRICAL PROPERTIES

Conductor Operating Temperature : 90°C

Ambient Temperature : 30°C

Current-Carrying Capacities (Amp)

Nominal Cross Section Area	Reference Method 1 (clipped direct)		Reference Method 11 (on perforated cable tray)		Reference Method 12 (free air)	In single-way ducts		Laid direct in ground	
	2 cables singlephase a.c. or d.c. flat and touching	3 or 4 cables 3-phase a.c. flat and touching	2 cables singlephase a.c. or d.c. flat and touching	3 or 4 cables 3-phase a.c. flat and touching	3 cables 3-phase a.c. trefoil touching	2 cables singlephase a.c. or d.c. ducts touching	3 cables 3-phase a.c. trefoil touching	2 cables singlephase a.c. or d.c. touching	3 cables 3-phase a.c. trefoil touching
1	2	3	4	5	6	7	8	9	10
mm ²	A	A	A	A	A	A	A	A	A
50	237	220	253	232	222	255	235	275	235
70	303	277	322	293	285	310	280	340	290
95	367	333	389	352	346	365	330	405	345
120	425	383	449	405	402	410	370	460	389
150	488	437	516	462	463	445	405	510	435
185	557	496	587	524	529	485	440	580	490
240	656	579	689	612	625	550	500	670	560
300	755	662	792	700	720	610	550	750	630
400	853	717	899	767	815	640	580	830	700
500	962	791	1016	851	918	690	620	910	770
630	1082	861	1146	935	1027	750	670	1000	840
800	1170	904	1246	987	1119	828	735	1117	931
1000	1261	961	1345	1055	1214	919	811	1254	1038

Voltage Drop (Per Amp Per Meter)

Nominal Cross Section Area	2 cables d.c.	2 cables single-phase a.c.	3 or 4 cables three-phase a.c.	2 cables singlephase a.c.	3 or 4 cables, 3-phase a.c. touching
----------------------------	---------------	----------------------------	--------------------------------	---------------------------	--------------------------------------

1	2	Reference Method 1 & 11 (touching)			Reference Method 1, 11 & 12 (in trefoil touching)			Reference Method 1 & 11 (Flat touching)			In ducts	In ground	In ducts	In ground
		3			4			5						
mm ²	mV/A/m	mV/A/m			mV/A/m			mV/A/m			mV/A/m	mV/A/m	mV/A/m	mV/A/m
		r	x	z	r	x	z	r	x	z				
50	0.98	0.99	0.21	1	0.86	0.18	0.87	0.84	0.25	0.88	1.1	0.99	0.93	0.86
70	0.67	0.68	0.2	0.71	0.59	0.17	0.62	0.6	0.25	0.65	0.8	0.7	0.7	0.61
95	0.49	0.51	0.195	0.55	0.44	0.17	0.47	0.46	0.24	0.52	0.65	0.53	0.56	0.46
120	0.39	0.41	0.19	0.45	0.35	0.165	0.39	0.38	0.24	0.44	0.55	0.43	0.48	0.37
150	0.31	0.33	0.185	0.38	0.29	0.16	0.33	0.31	0.23	0.39	0.5	0.37	0.43	0.32
185	0.25	0.27	0.185	0.33	0.23	0.16	0.28	0.26	0.23	0.34	0.45	0.31	0.39	0.27
240	0.195	0.21	0.18	0.28	0.18	0.155	0.24	0.21	0.22	0.3	0.4	0.26	0.35	0.23
300	0.155	0.17	0.175	0.25	0.145	0.15	0.21	0.17	0.22	0.28	0.37	0.24	0.32	0.21
400	0.115	0.145	0.17	0.22	0.125	0.15	0.195	0.16	0.21	0.27	0.35	0.21	0.3	0.19
500	0.093	0.125	0.17	0.21	0.105	0.145	0.18	0.145	0.2	0.25	0.33	0.2	0.28	0.18
630	0.073	0.105	0.165	0.195	0.092	0.145	0.17	0.135	0.195	0.24	0.3	0.19	0.26	0.17
800	0.056	0.09	0.16	0.19	0.086	0.14	0.165	0.13	0.18	0.23	0.28	0.18	0.24	0.16
1000	0.045	0.092	0.155	0.18	0.08	0.135	0.155	0.125	0.17	0.21	0.26	0.17	0.22	0.15

Note: r = conductor resistance at operating temperature

x = reactance

z = impedance



600/1000V



BS 6724
IEC 60502-1

Standard

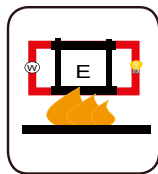

Circuit Integrity
IEC 60331/BS 6387
NF C32-070-2.3(CR1)



Reduced Fire Propagation
NF C32-070-2.2(C1)
IEC60332-3-24/EN50266-2-4



Flame Retardancy
NF C32-070-2.1(C2)
IEC60332-1-2/EN50265-2-1



Low Toxicity
NES 02-713/NF C 20-454



Low Corrosivity
IEC60754-2
EN50267-2-2/3
NF C 32-074



Low Smoke Emission
IEC 61034-1&2
EN 50268-1&2/NF C32-073

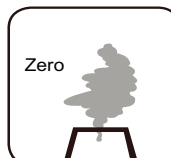

Zero
Halogen Free
IEC60754-1
EN50267-2-1

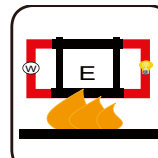

Functional Integrity
DIN 4102-12



300/500V Mica+XLPE Insulated, LSZH Sheathed Power Cables (2-4cores)

FFX200 05mRZ1-R (CU/MGT+XLPE/LSZH 300/500V Class 2)

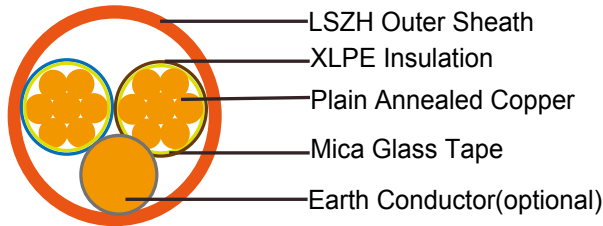
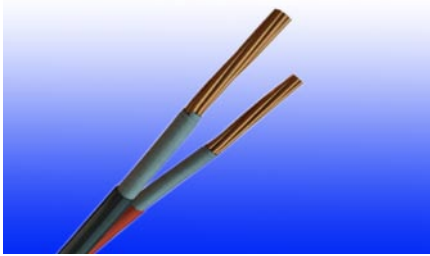

APPLICATION

The cables are designed for areas where the integrity of the electrical circuit is critical in maintaining power supply. Applications can be found in emergency lightings, control and power circuits, power stations, fire alarm systems, underground tunnels, lifts, escalators, and high-rise buildings.

STANDARDS

Basic design to IEC 60502-1

FIRE PERFORMANCE

Circuit Integrity	IEC 60331-21; BS 6387 CWZ; DIN VDE 0472-814(FE180); CEI 20-36/2-1; SS299-1; NBN C 30-004 (cat. F3); NF C32-070-2.3(CR1)
System Circuit Integrity	DIN 4102-12, E30 depending on lay system
Flame Retardance (Single Vertical Wire Test)	EN 60332-1-2; IEC 60332-1-2; BS EN 60332-1-2; VDE 0482-332-1 ; NBN C 30-004 (cat. F1); NF C32-070-2.1(C2); CEI 20-35/1-2; EN 50265-2-1*; DIN VDE 0482-265-2-1*
Reduced Fire Propagation (Vertically-mounted bundled wires & cable test)	EN 60332-3-24 (cat. C); IEC 60332-3-24; BS EN 60332-3-24; VDE 0482-332-3; NBN C 30-004 (cat. F2); NF C32-070-2.2(C1); CEI 20-22/3-4; EN 50266-2-4*; DIN VDE 0482-266-2-4
Halogen Free	IEC 60754-1; EN 50267-2-1; DIN VDE 0482-267-2-1; CEI 20-37/2-1 ; BS 6425-1*
No Corrosive Gas Emission	IEC 60754-2; EN 50267-2-2; DIN VDE 0482-267-2-2; CEI 20-37/2-2 ; BS 6425-2*
Minimum Smoke Emission	IEC 61034-1&2; EN 61034 -1&2; DIN VDE 0482-1034-1&2; CEI 20-37/3-1&2; EN 50268-1&2*; BS 7622-1&2*
No Toxic gases	NES 02-713; NF C 20-454

Note: Asterisk * denotes superseded standard.

VOLTAGE RATING

300/500 V

CABLE CONSTRUCTION

Conductor: Plain annealed copper wire, stranded according to IEC 60228 class 2.

Insulation: Mica glass tape covered by extruded cross-linked XLPE compound

Earth Conductor(optional): Uninsulated solid or stranded tinned copper conductor.

Cabling: The cores are cabled together in concentric layers with suitable non-hygroscopic fillers.

Outer Sheath: Thermoplastic LSZH compound type LTS3 as per BS 7655-6.1 (Thermosetting LSZH compound type SW2-SW4 as per BS 7655-2.6 can be offered.). UV resistance, hydrocarbon resistance, oil resistance, anti rodent and anti termite properties can be offered as option.

COLOUR CODE

Insulation Colour as per BS7671

	Without Earth Conductor
2Cores	Brown, Blue
3Cores	Brown, Gray, Black
4Cores	Brown, Gray, Black, Blue

Sheath Colour: Black (other colors upon request)

PHYSICAL AND THERMAL PROPERTIES

Temperature range during operation (fixed state): -30°C – +90°C

Temperature range during installation (mobile state): -20°C – +50°C

Minimum bending radius: 8 x Overall Diameter

ELECTRICAL PROPERTIES

Dielectric test:	2000 V r.m.s. x 5' (core/core)
Insulation resistance	1000 MΩ x km (at 20°C)
Short circuit temperature	250°C



CONSTRUCTION PARAMETERS

Conductor		Nominal Insulation Thickness	Nominal Sheath Thickness	FFX200 05mRZ1-R			
				Without Earth Conductor		With Earth Conductor	
No. of Core X Cross Section	No./Nominal Diameter of Strands	mm	mm	Nominal Overall Diameter	Approx. Weight	Nominal Overall Diameter	Approx. Weight
No*mm ²	No./mm	mm	mm	mm	kg/km	mm	kg/km
2 Core							
2x1.5	7/0.53	0.5	0.5	7.7	70	8.2	80
2x2.5	7/0.67	0.5	0.5	8.8	100	9.6	120
2x4	7/0.85	0.5	0.5	9.8	140	10.5	170
3 Core							
3x1.5	7/0.53	0.5	0.5	8.7	90	10.5	100
3x2.5	7/0.67	0.5	0.5	9.5	125	10.7	150
3x4	7/0.85	0.5	0.5	11.5	180	12.5	220
4 Core							
4x1.5	7/0.53	0.5	0.5	10.3	105	12.2	120
4x2.5	7/0.67	0.5	0.5	11	155	13	190
4x4	7/0.85	0.5	0.5	12.5	255	13.5	270

ELECTRICAL PROPERTIES

Conductor Operating Temperature : 90°C

Ambient Temperature : 30°C

Current-Carrying Capacities (Amp)

Nominal cross-section area	Reference Method 4 (enclosed in an conduit insulated wall etc)	Reference Method 3 (enclosed in conduit on a wall or ceiling, or in trunking)		Reference Method 1 (clipped direct)		Reference Method 11 (on a perforated cable tray), or Reference Method 13 (free air)	
	one 3-core cable or one 4-core cable 3-phase a.c.	one 2-core cable singlephase a.c. or d.c.	one 3-core cable or one 4-core cable 3-phase a.c.	one 2-core cable singlephase a.c. or d.c.	one 3-core cable or one 4-core cable 3-phase a.c.	one 2-core cable singlephase a.c. or d.c.	one 3-core cable or one 4-core cable 3-phase a.c.
1	2	3	4	5	6	7	8
mm ²	A	A	A	A	A	A	A
1.5	16.5	22	19.5	24	22	26	23
2.5	22	30	26	33	30	36	32
4	30	40	35	45	40	49	42

Voltage Drop (Per Amp Per Meter)

Nominal Cross Section Area	2-core cable d.c.	2-core cable single-phase a.c.	3-core or 4-core cable 3-phase a.c.
1	2	3	4
mm ²	mV/A/m	mV/A/m	mV/A/m
1.5	31	31	27
2.5	19	19	16
4	12	12	10



300/500V

Rated Voltage



IEC 60502-1

Standard

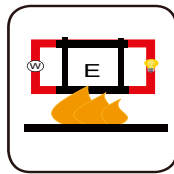

Circuit Integrity
IEC 60331/BS 6387
NF C32-070-2.3(CR1)



Reduced Fire Propagation
NF C32-070-2.2(C1)
IEC60332-3-24/EN50266-2-4



Flame Retardancy
NF C32-070-2.1(C2)
IEC60332-1-2/EN50265-2-1



Low Toxicity
NES 02-713/NF C 20-454



Low Corrosivity
IEC60754-2
EN50267-2-2/3
NF C 32-074



Low Smoke Emission
IEC 61034-1&2
EN 50268-1&2/NF C32-073

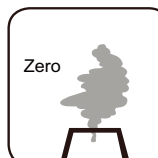

Halogen Free
IEC60754-1
EN50267-2-1

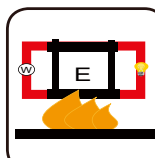

Functional Integrity
DIN 4102-12



600/1000V Mica+XLPE Insulated, LSZH Sheathed Power Cables (2-4 Cores & Multicore)

FFX400 1mRZ1-R (CU/MGT+XLPE/LSZH 600/1000V Class 2)

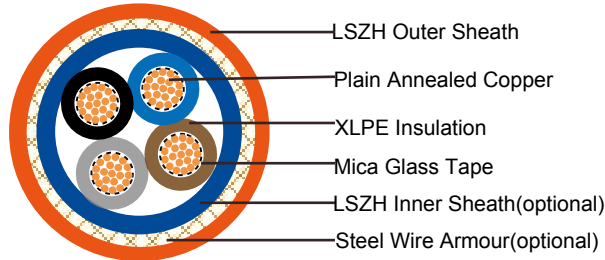
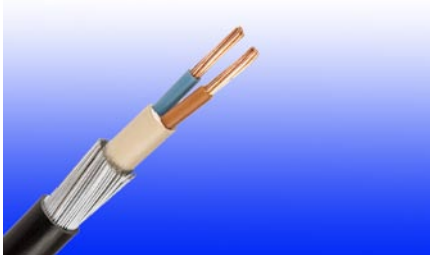

APPLICATION

This cable is designed for areas where the integrity of the electrical properties circuit is critical in maintaining power supply. Applications can be found in emergency lightings, control and power circuits, power stations, fire alarm systems, underground tunnels, communications systems, sewage treatment plants, lifts, escalators, and high-rise buildings.

STANDARDS

Basic design to IEC 60502-1/BS 7846

FIRE PERFORMANCE

Circuit Integrity	IEC 60331-21; BS 6387 CWZ; DIN VDE 0472-814(FE180); CEI 20-36/2-1; SS299-1; NBN C 30-004 (cat. F3); NF C32-070-2.3(CR1); BS 7846-(F2)
System Circuit Integrity	DIN 4102-12, E30 depending on lay system
Flame Retardance (Single Vertical Wire Test)	EN 60332-1-2; IEC 60332-1-2; BS EN 60332-1-2; VDE 0482-332-1 ; NBN C 30-004 (cat. F1); NF C32-070-2.1(C2); CEI 20-35/1-2; EN 50265-2-1*; DIN VDE 0482-265-2-1*
Reduced Fire Propagation (Vertically-mounted bundled wires & cable test)	EN 60332-3-24 (cat. C); IEC 60332-3-24; BS EN 60332-3-24; VDE 0482-332-3; NBN C 30-004 (cat. F2); NF C32-070-2.2(C1); CEI 20-22/3-4; EN 50266-2-4*; DIN VDE 0482-266-2-4
Halogen Free	IEC 60754-1; EN 50267-2-1; DIN VDE 0482-267-2-1; CEI 20-37/2-1 ; BS 6425-1*
No Corrosive Gas Emission	IEC 60754-2; EN 50267-2-2; DIN VDE 0482-267-2-2; CEI 20-37/2-2 ; BS 6425-2*
Minimum Smoke Emission	IEC 61034-1&2; EN 61034 -1&2; DIN VDE 0482-1034-1&2; CEI 20-37/3-1&2; EN 50268-1&2*; BS 7622-1&2*
No Toxic gases	NES 02-713; NF C 20-454

Note: Asterisk * denotes superseded standard.

VOLTAGE RATING

600/1000V

CABLE CONSTRUCTION

Conductor: Plain annealed copper wire, stranded according to IEC 60228 class 2.

Insulation: Mica glass tape covered by extruded cross-linked XLPE compound

Cabling: The cores are cabled together in concentric layers with suitable non-hygroscopic fillers.

Sheath: Thermoplastic LSZH compound type LTS3 as per BS 7655-6.1 (Thermosetting LSZH compound type SW2-SW4 as per BS 7655-2.6 can be offered.). UV resistance, hydrocarbon resistance, oil resistance, anti rodent and anti termite properties can be offered as option.

COLOUR CODE

Insulation Colour as per BS7671

	With Earth Conductor	Without Earth Conductor
2Cores	-	Brown, Blue
3Cores	Yellow/Green, Brown, Blue	Brown, Gray, Black
4Cores	Yellow/Green, Brown, Gray, Black	Brown, Gray, Black, Blue
5Cores	Yellow/Green, Brown, Gray, Black, Blue	Brown, Gray, Black, Blue, Black
above 5 Cores	Yellow/Green, Black Numbered	Black Numbered

Sheath Colour: Black (other colors upon request)

PHYSICAL AND THERMAL PROPERTIES

Temperature range during operation (fixed state): -30°C – +90°C

Temperature range during installation (mobile state): -20°C – +50°C

Minimum bending radius: 8 x Overall Diameter (unarmoured cable)

10 x Overall Diameter (armoured cable)

ELECTRICAL PROPERTIES

Dielectric test:	3500 V r.m.s. x 5' (core/core)
Insulation resistance	1000 MΩ x km (at 20°C)
Short circuit temperature	250°C

CONSTRUCTION PARAMETERS

Conductor		FFX400 1mRZ1-R		
Cable Code	No./Nominal Diameter of Strands	Nominal Insulation Thickness	Nominal Overall Diameter	Approx. Weight
	No./mm	mm	mm	kg/km
2Cores				
FFX400 1mRZ1-R 2G1.5	7/0.53	0.7	12.2	150
FFX400 1mRZ1-R 2G2.5	7/0.67	0.7	12.6	180
FFX400 1mRZ1-R 2G4	7/0.85	0.7	14.7	250
FFX400 1mRZ1-R 2G6	7/1.04	0.7	16.2	290
FFX400 1mRZ1-R 2G10	7/1.35	0.7	17.1	450
FFX400 1mRZ1-R 2G16	7/1.70	0.7	19.2	550
FFX400 1mRZ1-R 2G25	7/2.14	0.9	20	680
FFX400 1mRZ1-R 2G35	19/1.53	0.9	22	940
FFX400 1mRZ1-R 2G50	19/1.78	1	24	1250
FFX400 1mRZ1-R 2G70	19/2.14	1.1	27	1700



Conductor		FFX400 1mRZ1-R		
Cable Code	No./Nominal Diameter of Strands	Nominal Insulation Thickness	Nominal Overall Diameter	Approx. Weight
	No./mm	mm	mm	kg/km
FFX400 1mRZ1-R 2G95	19/2.52	1.1	31	2300
FFX400 1mRZ1-R 2G120	37/2.03	1.2	36	3150
3Cores				
FFX400 1mRZ1-R 3G1.5	7/0.53	0.7	12.3	170
FFX400 1mRZ1-R 3G2.5	7/0.67	0.7	13.8	200
FFX400 1mRZ1-R 3G4	7/0.85	0.7	15.2	300
FFX400 1mRZ1-R 3G6	7/1.04	0.7	16.8	380
FFX400 1mRZ1-R 3G10	7/1.35	0.7	18	550
FFX400 1mRZ1-R 3G16	1/1.70	0.7	21	760
FFX400 1mRZ1-R 3G25	7/2.14	0.9	22	960
FFX400 1mRZ1-R 3G35	19/1.53	0.9	24	1300
FFX400 1mRZ1-R 3G50	19/1.78	1	28	1700
FFX400 1mRZ1-R 3G70	19/2.14	1.1	31	2400
FFX400 1mRZ1-R 3G95	19/2.52	1.1	36	3250
FFX400 1mRZ1-R 3G120	37/2.03	1.2	38	4000
FFX400 1mRZ1-R 3G150	37/2.25	1.4	42	5000
FFX400 1mRZ1-R 3G185	37/2.52	1.6	47	6100
FFX400 1mRZ1-R 3G240	61/2.25	1.7	52	8000
FFX400 1mRZ1-R 3G300	61/2.52	1.8	59	9850
FFX400 1mRZ1-R 3G400	61/2.85	2	63	13000
3Cores+1Core Earth Conductor				
FFX400 1mRZ1-R 3G10+6	7/1.35	0.7	18.6	580
FFX400 1mRZ1-R 3G16+10	7/1.70	0.7	19.7	810
FFX400 1mRZ1-R 3G25+10	7/2.14	0.9	22	1090
FFX400 1mRZ1-R 3G25+16	7/2.14	0.9	23	1150
FFX400 1mRZ1-R 3G35+16	19/1.53	0.9	26	1420
FFX400 1mRZ1-R 3G35+25	19/1.53	0.9	27	1490
FFX400 1mRZ1-R 3G50+16	19/1.78	1	29	1800
FFX400 1mRZ1-R 3G50+25	19/1.78	1	30	1890
FFX400 1mRZ1-R 3G50+35	19/1.78	1	31	1920
FFX400 1mRZ1-R 3G70+16	19/2.14	1.1	32	2200
FFX400 1mRZ1-R 3G70+25	19/2.14	1.1	33	2400
FFX400 1mRZ1-R 3G70+35	19/2.14	1.1	35	2900
FFX400 1mRZ1-R 3G70+50	19/2.14	1.1	36	3300
FFX400 1mRZ1-R 3G95+16	19/2.52	1.1	37	3560
FFX400 1mRZ1-R 3G95+25	19/2.52	1.1	38	3700
FFX400 1mRZ1-R 3G95+35	19/2.52	1.1	39	3910
FFX400 1mRZ1-R 3G95+50	19/2.52	1.1	40	4200
FFX400 1mRZ1-R 3G120+35	37/2.03	1.2	40	4250

Conductor		FFX400 1mRZ1-R		
Cable Code	No./Nominal Diameter of Strands	Nominal Insulation Thickness	Nominal Overall Diameter	Approx. Weight
	No./mm	mm	mm	kg/km
FFX400 1mRZ1-R 3G120+50	37/2.03	1.2	41	4300
FFX400 1mRZ1-R 3G120+70	37/2.03	1.2	42	4400
FFX400 1mRZ1-R 3G120+95	37/2.03	1.2	43	4600
FFX400 1mRZ1-R 3G150+50	37/2.25	1.4	44	5700
FFX400 1mRZ1-R 3G150+70	37/2.25	1.4	45	6700
FFX400 1mRZ1-R 3G150+95	37/2.25	1.4	46	6800
FFX400 1mRZ1-R 3G150+120	37/2.25	1.4	47	6900
FFX400 1mRZ1-R 3G185+70	37/2.52	1.6	49	7980
FFX400 1mRZ1-R 3G185+95	37/2.52	1.6	50	8050
FFX400 1mRZ1-R 3G185+120	37/2.52	1.6	51	8200
FFX400 1mRZ1-R 3G185+150	37/2.52	1.6	51	8400
FFX400 1mRZ1-R 3G240+70	61/2.25	1.7	52	8800
FFX400 1mRZ1-R 3G240+95	61/2.25	1.7	57	9000
FFX400 1mRZ1-R 3G240+120	61/2.25	1.7	58	9500
FFX400 1mRZ1-R 3G240+150	61/2.25	1.7	59	9700
FFX400 1mRZ1-R 3G300+95	61/2.52	1.8	60	10300
FFX400 1mRZ1-R 3G300+120	61/2.52	1.8	61	11050
FFX400 1mRZ1-R 3G300+150	61/2.52	1.8	62	12000
FFX400 1mRZ1-R 3G300+185	61/2.52	1.8	64	12800
FFX400 1mRZ1-R 3G300+240	61/2.52	1.8	67	13800
4Cores				
FFX400 1mRZ1-R 4G1.5	7/0.53	0.7	14.3	210
FFX400 1mRZ1-R 4G2.5	7/0.67	0.7	15.2	270
FFX400 1mRZ1-R 4G4	7/0.85	0.7	17.2	380
FFX400 1mRZ1-R 4G6	7/1.04	0.7	19	440
FFX400 1mRZ1-R 4G10	7/1.35	0.7	20.6	670
FFX400 1mRZ1-R 4G16	1/1.70	0.7	23.6	820
FFX400 1mRZ1-R 4G25	7/2.14	0.9	26	1320
FFX400 1mRZ1-R 4G35	19/1.53	0.9	29	1730
FFX400 1mRZ1-R 4G50	19/1.78	1	32	2300
FFX400 1mRZ1-R 4G70	19/2.14	1.1	38	3180
FFX400 1mRZ1-R 4G95	19/2.52	1.1	41.9	4370
FFX400 1mRZ1-R 4G120	37/2.03	1.2	44	5400
FFX400 1mRZ1-R 4G150	37/2.25	1.4	50.8	6500
FFX400 1mRZ1-R 4G185	37/2.52	1.6	55	8200
FFX400 1mRZ1-R 4G240	61/2.25	1.7	60.5	10600
FFX400 1mRZ1-R 4G300	61/2.52	1.8	68.5	13200
FFX400 1mRZ1-R 4G400	61/2.85	2	76	17000
4Cores+1Core Earth Conductor				
FFX400 1mRZ1-R 4G10+6	7/1.35	0.7	21	740



Conductor		FFX400 1mRZ1-R		
Cable Code	No./Nominal Diameter of Strands	Nominal Insulation Thickness	Nominal Overall Diameter	Approx. Weight
	No./mm	mm	mm	kg/km
FFX400 1mRZ1-R 4G16+10	7/1.70	0.7	22	900
FFX400 1mRZ1-R 4G25+10	7/2.14	0.7	24	1200
FFX400 1mRZ1-R 4G25+16	7/2.14	0.7	25	1450
FFX400 1mRZ1-R 4G35+16	19/1.53	0.9	29.4	1800
FFX400 1mRZ1-R 4G35+25	19/1.53	0.9	29.6	1890
FFX400 1mRZ1-R 4G50+16	19/1.78	1	33	2400
FFX400 1mRZ1-R 4G50+25	19/1.78	1	35.8	2560
FFX400 1mRZ1-R 4G50+35	19/1.78	1	36.8	2730
FFX400 1mRZ1-R 4G70+16	19/2.14	1.1	40	3350
FFX400 1mRZ1-R 4G70+25	19/2.14	1.1	41	3500
FFX400 1mRZ1-R 4G70+35	19/2.14	1.1	41.5	3800
FFX400 1mRZ1-R 4G70+50	19/2.14	1.1	41.7	4600
FFX400 1mRZ1-R 4G95+16	19/2.52	1.1	41.8	5300
FFX400 1mRZ1-R 4G95+25	19/2.52	1.1	42.6	5700
FFX400 1mRZ1-R 4G95+35	19/2.52	1.1	43.4	6390
FFX400 1mRZ1-R 4G95+50	19/2.52	1.1	43.9	6600
FFX400 1mRZ1-R 4G120+35	37/2.03	1.2	44	6400
FFX400 1mRZ1-R 4G120+50	37/2.03	1.2	45	6500
FFX400 1mRZ1-R 4G120+70	37/2.03	1.2	46	6600
FFX400 1mRZ1-R 4G120+95	37/2.03	1.2	47	6700
FFX400 1mRZ1-R 4G150+50	37/2.25	1.4	52	7600
FFX400 1mRZ1-R 4G150+70	37/2.25	1.4	53	7800
FFX400 1mRZ1-R 4G150+95	37/2.25	1.4	54	7900
FFX400 1mRZ1-R 4G150+120	37/2.25	1.4	55	8100
FFX400 1mRZ1-R 4G185+70	37/2.52	1.6	56	8400
FFX400 1mRZ1-R 4G185+95	37/2.52	1.6	57	8800
FFX400 1mRZ1-R 4G185+120	37/2.52	1.6	58	9200
FFX400 1mRZ1-R 4G185+150	37/2.52	1.6	60	9700
FFX400 1mRZ1-R 4G240+70	61/2.25	1.7	62	10800
FFX400 1mRZ1-R 4G240+95	61/2.25	1.7	65	11400
FFX400 1mRZ1-R 4G240+120	61/2.25	1.7	66	11900
FFX400 1mRZ1-R 4G240+150	61/2.25	1.7	68	12400
FFX400 1mRZ1-R 4G300+95	61/2.52	1.8	69	12800
FFX400 1mRZ1-R 4G300+120	61/2.52	1.8	70	13400
FFX400 1mRZ1-R 4G300+150	61/2.52	1.8	71	13900
FFX400 1mRZ1-R 4G300+185	61/2.52	1.8	74	14800
FFX400 1mRZ1-R 4G300+240	61/2.52	1.8	76	16200
5Cores				
FFX400 1mRZ1-R 5G1.5	7/0.53	0.7	16.8	247
FFX400 1mRZ1-R 5G2.5	7/0.67	0.7	17.9	317

Conductor		FFX400 1mRZ1-R		
Cable Code	No./Nominal Diameter of Strands	Nominal Insulation Thickness	Nominal Overall Diameter	Approx. Weight
	No./mm	mm	mm	kg/km
FFX400 1mRZ1-R 5G4	7/0.85	0.7	20.2	447
FFX400 1mRZ1-R 5G6	7/1.04	0.7	22.3	517
FFX400 1mRZ1-R 5G10	7/1.35	0.7	24.2	787
FFX400 1mRZ1-R 5G16	1/1.70	0.7	27.7	964
FFX400 1mRZ1-R 5G25	7/2.14	0.9	30.6	1551
FFX400 1mRZ1-R 5G35	19/1.53	0.9	34.1	2033
FFX400 1mRZ1-R 5G50	19/1.78	1	37.6	2703
FFX400 1mRZ1-R 5G70	19/2.14	1.1	44.7	3737
FFX400 1mRZ1-R 5G95	19/2.52	1.1	49.2	5135
FFX400 1mRZ1-R 5G120	37/2.03	1.2	51.7	6345
FFX400 1mRZ1-R 5G150	37/2.25	1.4	59.7	7638
FFX400 1mRZ1-R 5G185	37/2.52	1.6	64.6	9635
FFX400 1mRZ1-R 5G240	61/2.25	1.7	71.1	12455
FFX400 1mRZ1-R 5G300	61/2.52	1.8	80.5	15510
FFX400 1mRZ1-R 5G400	61/2.85	2	89.3	19975

ELECTRICAL PROPERTIES

Conductor Operating Temperature : 90°C

Ambient Temperature : 30°C

Current-Carrying Capacities (Amp)

Nominal Cross Section Area	Reference Method 4 (enclosed in an conduit insulated wall etc)	Reference Method 3 (enclosed in conduit on a wall or ceiling, or in trunking)		Reference Method 1 (clipped direct)		Reference Method 11 (on a perforated cable tray), or Reference Method 13 (free air)	
	one 3-core cable or one 4-core cable 3-phase a.c.	one 2-core cable single phase a.c. or d.c.	one 3-core cable or one 4-core cable 3-phase a.c.	one 2-core cable single phase a.c. or d.c.	one 3-core cable or one 4-core cable 3-phase a.c.	one 2-core cable singlephase	one 3-core cable or one
						a.c. or d.c.	4-core cable 3-phase a.c.
1	2	3	4	5	6	7	8
mm ²	A	A	A	A	A	A	A
1.5	16.5	22	19.5	24	22	26	23
2.5	22	30	26	33	30	36	32
4	30	40	35	45	40	49	42
6	38	51	44	58	52	63	54
10	51	69	60	80	71	86	75
16	68	91	80	107	96	115	100
25	89	119	105	138	119	149	127
35	109	146	128	171	147	185	158
50	130	175	154	209	179	225	192
70	164	221	194	269	229	289	246
95	197	265	233	328	278	352	298



120	227	305	268	382	322	410	346
150	259	334	300	441	371	473	399
185	295	384	340	506	424	542	456
240	346	459	398	599	500	641	538
300	396	532	455	693	576	741	621
400	-	625	536	803	667	865	741

Voltage Drop (Per Amp Per Meter)

Nominal Cross Section Area	2-core cable d.c.	2-core cable single-phase a.c			3-core or 4-core cable 3-phase a.c.		
1	2	3			4		
mm ²	mV/A/m	mV/A/m			mV/A/m		
1.5	31	31			27		
2.5	19	19			16		
4	12	12			10		
6	7.9	7.9			6.8		
10	4.7	4.7			4		
16	2.9	2.9			2.5		
		r	x	z	r	x	z
25	1.85	1.85	0.16	1.9	1.6	0.14	1.65
35	1.35	1.35	0.155	1.35	1.15	0.135	1.15
50	0.98	0.99	0.155	1	0.86	0.135	0.87
70	0.67	0.67	0.15	0.69	0.59	0.13	0.6
95	0.49	0.5	0.15	0.52	0.43	0.13	0.45
120	0.39	0.4	0.145	0.42	0.34	0.13	0.37
150	0.31	0.32	0.145	0.35	0.28	0.125	0.3
185	0.25	0.26	0.145	0.29	0.22	0.125	0.26
240	0.195	0.2	0.14	0.24	0.175	0.125	0.21
300	0.155	0.16	0.14	0.21	0.14	0.12	0.185
400	0.12	0.13	0.14	0.19	0.115	0.12	0.165



600/1000V

Rated Voltage



BS 7846
IEC 60502-1

Standard

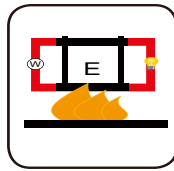

Circuit Integrity
IEC 60331/BS 6387
NF C32-070-2.3(CR1)



Reduced Fire Propagation
NF C32-070-2.2(C1)
IEC60332-3-24/EN50266-2-4



Flame Retardancy
NF C32-070-2.1(C2)
IEC60332-1-2/EN50265-2-1



Low Toxicity
NES 02-713/NF C 20-454



Low Corrosivity
IEC60754-2
EN50267-2-2/3
NF C 32-074



Low Smoke Emission
IEC 61034-1&2
EN 50268-1&2/NF C32-073

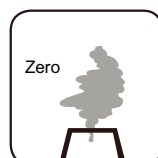

Zero
Halogen Free
IEC60754-1
EN50267-2-1

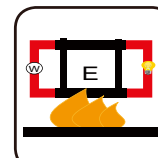

Functional Integrity
DIN 4102-12

600/1000V Mica+XLPE Insulated, LSZH Sheathed Power Cables (2-4 Cores & Multicore)

FFX400 1mRZ1MZ1-R (CU/MGT+XLPE/LSZH/SWA/LSZH 600/1000V Class 2)

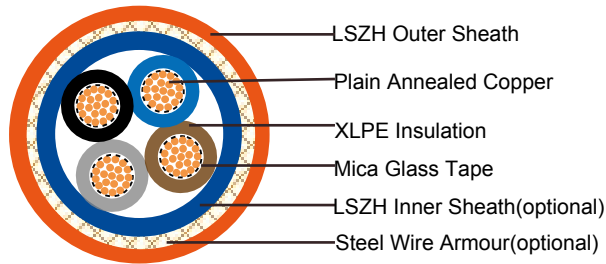
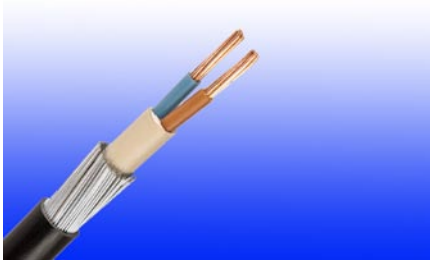

APPLICATION

This cable is designed for areas where the integrity of the electrical properties circuit is critical in maintaining power supply. Applications can be found in emergency lightings, control and power circuits, power stations, fire alarm systems, underground tunnels, communications systems, sewage treatment plants, lifts, escalators, and high-rise buildings.

STANDARDS

Basic design to IEC 60502-1/BS 7846

FIRE PERFORMANCE

Circuit Integrity	IEC 60331-21; BS 6387 CWZ; DIN VDE 0472-814(FE180); CEI 20-36/2-1; SS299-1; NBN C 30-004 (cat. F3); NF C32-070-2.3(CR1); BS 7846-(F2)
System Circuit Integrity	DIN 4102-12, E30 depending on lay system
Flame Retardance (Single Vertical Wire Test)	EN 60332-1-2; IEC 60332-1-2; BS EN 60332-1-2; VDE 0482-332-1 ; NBN C 30-004 (cat. F1); NF C32-070-2.1(C2); CEI 20-35/1-2; EN 50265-2-1*; DIN VDE 0482-265-2-1*
Reduced Fire Propagation (Vertically-mounted bundled wires & cable test)	EN 60332-3-24 (cat. C); IEC 60332-3-24; BS EN 60332-3-24; VDE 0482-332-3; NBN C 30-004 (cat. F2); NF C32-070-2.2(C1); CEI 20-22/3-4; EN 50266-2-4*; DIN VDE 0482-266-2-4
Halogen Free	IEC 60754-1; EN 50267-2-1; DIN VDE 0482-267-2-1; CEI 20-37/2-1 ; BS 6425-1*
No Corrosive Gas Emission	IEC 60754-2; EN 50267-2-2; DIN VDE 0482-267-2-2; CEI 20-37/2-2 ; BS 6425-2*
Minimum Smoke Emission	IEC 61034-1&2; EN 61034 -1&2; DIN VDE 0482-1034-1&2; CEI 20-37/3-1&2; EN 50268-1&2*; BS 7622-1&2*
No Toxic gases	NES 02-713; NF C 20-454

Note: Asterisk * denotes superseded standard.

VOLTAGE RATING

600/1000V



CABLE CONSTRUCTION

Conductor: Plain annealed copper wire, stranded according to IEC 60228 class 2.

Insulation: Mica glass tape covered by extruded cross-linked XLPE compound

Cabling: The cores are cabled together in concentric layers with suitable non-hygroscopic fillers.

Inner Sheath(optional): Thermoplastic LSZH compound type LTS3 as per BS 7655-6.1

Armouring(optional): Galvanized steel wire armour

Outer Sheath: Thermoplastic LSZH compound type LTS3 as per BS 7655-6.1 (Thermosetting LSZH compound type SW2-SW4 as per BS 7655-2.6 can be offered.). UV resistance, hydrocarbon resistance, oil resistance, anti rodent and anti termite properties can be offered as option.

COLOUR CODE

Insulation Colour as per BS7671

	With Earth Conductor	Without Earth Conductor
2Cores	-	Brown, Blue
3Cores	Yellow/Green, Brown, Blue	Brown, Gray, Black
4Cores	Yellow/Green, Brown, Gray, Black	Brown, Gray, Black, Blue
5Cores	Yellow/Green, Brown, Gray, Black, Blue	Brown, Gray, Black, Blue, Black
above 5 Cores	Yellow/Green, Black Numbered	Black Numbered

Sheath Colour: Black (other colors upon request)

PHYSICAL AND THERMAL PROPERTIES

Temperature range during operation (fixed state): -30°C – +90°C

Temperature range during installation (mobile state): -20°C – +50°C

Minimum bending radius: 8 x Overall Diameter (unarmoured cable)

10 x Overall Diameter (armoured cable)

ELECTRICAL PROPERTIES

Dielectric test:	3500 V r.m.s. x 5' (core/core)
Insulation resistance	1000 MΩ x km (at 20°C)
Short circuit temperature	250°C

CONSTRUCTION PARAMETERS

Conductor		FFX400 1mRZ1MZ1-R		
Cable Code	No./Nominal Diameter of Strands	Nominal Insulation Thickness	Nominal Overall Diameter	Approx. Weight
	No./mm	mm	mm	kg/km
2Cores				
FFX400 1mRZ1-R 2G1.5	7/0.53	0.7	15.3	390
FFX400 1mRZ1-R 2G2.5	7/0.67	0.7	16.5	450
FFX400 1mRZ1-R 2G4	7/0.85	0.7	17.6	525
FFX400 1mRZ1-R 2G6	7/1.04	0.7	18.8	620
FFX400 1mRZ1-R 2G10	7/1.35	0.7	21	800
FFX400 1mRZ1-R 2G16	7/1.70	0.7	23	1100
FFX400 1mRZ1-R 2G25	7/2.14	0.9	27	1480
FFX400 1mRZ1-R 2G35	19/1.53	0.9	30	2000
FFX400 1mRZ1-R 2G50	19/1.78	1	33	2450

Conductor		FFX400 1mRZ1MZ1-R		
Cable Code	No./Nominal Diameter of Strands	Nominal Insulation Thickness	Nominal Overall Diameter	Approx. Weight
	No./mm	mm	mm	kg/km
FFX400 1mRZ1-R 2G70	19/2.14	1.1	37	3200
FFX400 1mRZ1-R 2G95	19/2.52	1.1	42	4350
FFX400 1mRZ1-R 2G120	37/2.03	1.2	48	6500
3Cores				
FFX400 1mRZ1-R 3G1.5	7/0.53	0.7	16.5	420
FFX400 1mRZ1-R 3G2.5	7/0.67	0.7	17	500
FFX400 1mRZ1-R 3G4	7/0.85	0.7	18.5	600
FFX400 1mRZ1-R 3G6	7/1.04	0.7	19.8	785
FFX400 1mRZ1-R 3G10	7/1.35	0.7	22.6	1030
FFX400 1mRZ1-R 3G16	1/1.70	0.7	25	1370
FFX400 1mRZ1-R 3G25	7/2.14	0.9	29	1900
FFX400 1mRZ1-R 3G35	19/1.53	0.9	32	2300
FFX400 1mRZ1-R 3G50	19/1.78	1	35	2900
FFX400 1mRZ1-R 3G70	19/2.14	1.1	40	4000
FFX400 1mRZ1-R 3G95	19/2.52	1.1	45	5400
FFX400 1mRZ1-R 3G120	37/2.03	1.2	49	6450
FFX400 1mRZ1-R 3G150	37/2.25	1.4	55	8200
FFX400 1mRZ1-R 3G185	37/2.52	1.6	60	9800
FFX400 1mRZ1-R 3G240	61/2.25	1.7	68	12300
FFX400 1mRZ1-R 3G300	61/2.52	1.8	74	14800
FFX400 1mRZ1-R 3G400	61/2.85	2	83	17600
3Cores+1Core Earth Conductor				
FFX400 1mRZ1-R 3G10+6	7/1.35	0.7	22.9	1100
FFX400 1mRZ1-R 3G16+10	7/1.70	0.7	25.7	1385
FFX400 1mRZ1-R 3G25+10	7/2.14	0.9	27.3	1980
FFX400 1mRZ1-R 3G25+16	7/2.14	0.9	29.8	2070
FFX400 1mRZ1-R 3G35+16	19/1.53	0.9	30.5	2190
FFX400 1mRZ1-R 3G35+25	19/1.53	0.9	32.8	2400
FFX400 1mRZ1-R 3G50+16	19/1.78	1	36	3100
FFX400 1mRZ1-R 3G50+25	19/1.78	1	36.6	3250
FFX400 1mRZ1-R 3G50+35	19/1.78	1	37.3	3360
FFX400 1mRZ1-R 3G70+16	19/2.14	1.1	38	3600
FFX400 1mRZ1-R 3G70+25	19/2.14	1.1	41	3990
FFX400 1mRZ1-R 3G70+35	19/2.14	1.1	42	4760
FFX400 1mRZ1-R 3G70+50	19/2.14	1.1	44	5120
FFX400 1mRZ1-R 3G95+16	19/2.52	1.1	45.8	5600
FFX400 1mRZ1-R 3G95+25	19/2.52	1.1	46.7	6150
FFX400 1mRZ1-R 3G95+35	19/2.52	1.1	47.2	6340
FFX400 1mRZ1-R 3G95+50	19/2.52	1.1	47.8	6500
FFX400 1mRZ1-R 3G120+35	37/2.03	1.2	49	6600



Conductor		FFX400 1mRZ1MZ1-R		
Cable Code	No./Nominal Diameter of Strands	Nominal Insulation Thickness	Nominal Overall Diameter	Approx. Weight
	No./mm	mm	mm	kg/km
FFX400 1mRZ1-R 3G120+50	37/2.03	1.2	50.5	6990
FFX400 1mRZ1-R 3G120+70	37/2.03	1.2	51	7200
FFX400 1mRZ1-R 3G120+95	37/2.03	1.2	52.3	7600
FFX400 1mRZ1-R 3G150+50	37/2.25	1.4	57	9000
FFX400 1mRZ1-R 3G150+70	37/2.25	1.4	59	10600
FFX400 1mRZ1-R 3G150+95	37/2.25	1.4	60	10900
FFX400 1mRZ1-R 3G150+120	37/2.25	1.4	61	11100
FFX400 1mRZ1-R 3G185+70	37/2.52	1.6	63	11650
FFX400 1mRZ1-R 3G185+95	37/2.52	1.6	64	12000
FFX400 1mRZ1-R 3G185+120	37/2.52	1.6	65	12300
FFX400 1mRZ1-R 3G185+150	37/2.52	1.6	67	12700
FFX400 1mRZ1-R 3G240+70	61/2.25	1.7	70	12900
FFX400 1mRZ1-R 3G240+95	61/2.25	1.7	71	13500
FFX400 1mRZ1-R 3G240+120	61/2.25	1.7	73	14000
FFX400 1mRZ1-R 3G240+150	61/2.25	1.7	74	14700
FFX400 1mRZ1-R 3G300+95	61/2.52	1.8	75	15600
FFX400 1mRZ1-R 3G300+120	61/2.52	1.8	76	15720
FFX400 1mRZ1-R 3G300+150	61/2.52	1.8	77	16000
FFX400 1mRZ1-R 3G300+185	61/2.52	1.8	79	17560
FFX400 1mRZ1-R 3G300+240	61/2.52	1.8	86	18900
4Cores				
FFX400 1mRZ1-R 4G1.5	7/0.53	0.7	16	475
FFX400 1mRZ1-R 4G2.5	7/0.67	0.7	17.8	570
FFX400 1mRZ1-R 4G4	7/0.85	0.7	19.8	690
FFX400 1mRZ1-R 4G6	7/1.04	0.7	21	940
FFX400 1mRZ1-R 4G10	7/1.35	0.7	23.3	1200
FFX400 1mRZ1-R 4G16	1/1.70	0.7	26.5	1400
FFX400 1mRZ1-R 4G25	7/2.14	0.9	30.5	2400
FFX400 1mRZ1-R 4G35	19/1.53	0.9	34	2800
FFX400 1mRZ1-R 4G50	19/1.78	1	38	3500
FFX400 1mRZ1-R 4G70	19/2.14	1.1	44	5300
FFX400 1mRZ1-R 4G95	19/2.52	1.1	48.5	6700
FFX400 1mRZ1-R 4G120	37/2.03	1.2	54	8500
FFX400 1mRZ1-R 4G150	37/2.25	1.4	59	10000
FFX400 1mRZ1-R 4G185	37/2.52	1.6	64.5	12200
FFX400 1mRZ1-R 4G240	61/2.25	1.7	74	15400
FFX400 1mRZ1-R 4G300	61/2.52	1.8	82	19500
FFX400 1mRZ1-R 4G400	61/2.85	2	92	25500
4Cores+1Core Earth Conductor				

Conductor		FFX400 1mRZ1MZ1-R		
Cable Code	No./Nominal Diameter of Strands	Nominal Insulation Thickness	Nominal Overall Diameter	Approx. Weight
	No./mm	mm	mm	kg/km
FFX400 1mRZ1-R 4G10+6	7/1.35	0.7	24	1300
FFX400 1mRZ1-R 4G16+10	7/1.70	0.7	26	1600
FFX400 1mRZ1-R 4G25+10	7/2.14	0.7	29	2015
FFX400 1mRZ1-R 4G25+16	7/2.14	0.7	32	2540
FFX400 1mRZ1-R 4G35+16	19/1.53	0.9	35	3000
FFX400 1mRZ1-R 4G35+25	19/1.53	0.9	35.6	3170
FFX400 1mRZ1-R 4G50+16	19/1.78	1	40	3800
FFX400 1mRZ1-R 4G50+25	19/1.78	1	41.4	4100
FFX400 1mRZ1-R 4G50+35	19/1.78	1	42.9	4350
FFX400 1mRZ1-R 4G70+16	19/2.14	1.1	45	6270
FFX400 1mRZ1-R 4G70+25	19/2.14	1.1	47	6900
FFX400 1mRZ1-R 4G70+35	19/2.14	1.1	48	7200
FFX400 1mRZ1-R 4G70+50	19/2.14	1.1	50	7600
FFX400 1mRZ1-R 4G95+16	19/2.52	1.1	51	8000
FFX400 1mRZ1-R 4G95+25	19/2.52	1.1	52	8100
FFX400 1mRZ1-R 4G95+35	19/2.52	1.1	53	8250
FFX400 1mRZ1-R 4G95+50	19/2.52	1.1	54	8390
FFX400 1mRZ1-R 4G120+35	37/2.03	1.2	54	8600
FFX400 1mRZ1-R 4G120+50	37/2.03	1.2	55	8800
FFX400 1mRZ1-R 4G120+70	37/2.03	1.2	56	9100
FFX400 1mRZ1-R 4G120+95	37/2.03	1.2	57	9400
FFX400 1mRZ1-R 4G150+50	37/2.25	1.4	61	10800
FFX400 1mRZ1-R 4G150+70	37/2.25	1.4	62	11100
FFX400 1mRZ1-R 4G150+95	37/2.25	1.4	64	11500
FFX400 1mRZ1-R 4G150+120	37/2.25	1.4	65	11900
FFX400 1mRZ1-R 4G185+70	37/2.52	1.6	66	12900
FFX400 1mRZ1-R 4G185+95	37/2.52	1.6	68	13600
FFX400 1mRZ1-R 4G185+120	37/2.52	1.6	70	14700
FFX400 1mRZ1-R 4G185+150	37/2.52	1.6	73	15500
FFX400 1mRZ1-R 4G240+70	61/2.25	1.7	76	16000
FFX400 1mRZ1-R 4G240+95	61/2.25	1.7	77	16900
FFX400 1mRZ1-R 4G240+120	61/2.25	1.7	78	17600
FFX400 1mRZ1-R 4G240+150	61/2.25	1.7	79	18200
FFX400 1mRZ1-R 4G300+95	61/2.52	1.8	81	19700
FFX400 1mRZ1-R 4G300+120	61/2.52	1.8	82	20700
FFX400 1mRZ1-R 4G300+150	61/2.52	1.8	84	21060
FFX400 1mRZ1-R 4G300+185	61/2.52	1.8	85	22170
FFX400 1mRZ1-R 4G300+240	61/2.52	1.8	87	24500
5Cores				
FFX400 1mRZ1-R 5G1.5	7/0.53	0.7	18.8	558
FFX400 1mRZ1-R 5G2.5	7/0.67	0.7	20.9	670



Conductor		FFX400 1mRZ1MZ1-R		
Cable Code	No./Nominal Diameter of Strands	Nominal Insulation Thickness	Nominal Overall Diameter	Approx. Weight
	No./mm	mm	mm	kg/km
FFX400 1mRZ1-R 5G4	7/0.85	0.7	23.3	811
FFX400 1mRZ1-R 5G6	7/1.04	0.7	24.7	1105
FFX400 1mRZ1-R 5G10	7/1.35	0.7	27.4	1410
FFX400 1mRZ1-R 5G16	1/1.70	0.7	31.1	1645
FFX400 1mRZ1-R 5G25	7/2.14	0.9	35.8	2820
FFX400 1mRZ1-R 5G35	19/1.53	0.9	40.0	3290
FFX400 1mRZ1-R 5G50	19/1.78	1	44.7	4113
FFX400 1mRZ1-R 5G70	19/2.14	1.1	51.7	6228
FFX400 1mRZ1-R 5G95	19/2.52	1.1	57.0	7873
FFX400 1mRZ1-R 5G120	37/2.03	1.2	63.5	9988
FFX400 1mRZ1-R 5G150	37/2.25	1.4	69.3	11750
FFX400 1mRZ1-R 5G185	37/2.52	1.6	75.8	14335
FFX400 1mRZ1-R 5G240	61/2.25	1.7	87.0	18095
FFX400 1mRZ1-R 5G300	61/2.52	1.8	96.4	22913
FFX400 1mRZ1-R 5G400	61/2.85	2	108.1	29963

ELECTRICAL PROPERTIES

Conductor Operating Temperature : 90°C

Ambient Temperature : 30°C

Current-Carrying Capacities (Amp)

Nominal Cross Section Area	Reference Method 1 (clipped direct)		Reference Method 11 (on a perforated horizontal cable tray or Reference Method 13 [free air])		In single-way ducts		Laid direct in ground	
	one 2-core cable single phase a.c. or d.c.	one 3-core or 4-core cable 3-phase a.c.	one 2-core cable single phase a.c. or d.c.	one 3-core or 4-core cable 3-phase a.c.	one 2-core cable single phase a.c. or d.c.	one 3-core or 4-core cable 3-phase a.c.	one 2-core cable single phase a.c. or d.c.	one 3-core or 4-core cable 3-phase a.c.
1	2	3	4	5	6	7	8	9
mm ²	A	A	A	A	A	A	A	A
1.5	27	23	29	25	-	23	-	28
2.5	36	31	39	33	-	30	-	36
4	49	42	52	44	-	40	-	48
6	62	53	66	56	-	50	-	60
10	85	73	90	78	-	65	-	80
16	110	94	115	99	115	94	140	115
25	146	124	152	131	145	125	180	150
35	180	154	188	162	175	150	215	180
50	219	187	228	197	210	175	255	215
70	279	238	291	251	260	215	315	265
95	338	289	354	304	310	260	380	315
120	392	335	410	353	355	300	430	360
150	451	386	472	406	400	335	480	405

185	515	441	539	463	455	380	540	460
240	607	520	636	546	520	440	630	530
300	698	599	732	628	590	495	700	590
400	787	673	847	728	660	560	790	670

Voltage Drop (Per Amp Per Meter)

Nominal Cross Section Area 1	2-core cable d.c.	2 cables, single-phase a.c.			3 or 4 cables, 3-phase a.c.			2 cables, single-phase a.c. In ducts or in ground 5	3 or 4 cables, 3-phase a.c. In ducts or in ground 6
	2	3			4				
mm ²	mV/A/m	mV/A/m			mV/A/m			mV/A/m	mV/A/m
1.5	31	31			27			31	25
2.5	19	19			16			19	15
4	12	12			10			12	9.7
6	7.9	7.9			6.8			7.9	6.5
10	4.7	4.7			4			4.7	3.9
16	2.9	2.9			2.5			2.9	2.6
		r	x	z	r	x	z		
25	1.85	1.35	0.16	1.9	1.6	0.14	1.65	1.9	1.6
35	1.35	1.35	0.155	1.35	1.15	0.135	1.15	1.35	1.2
50	0.98	0.99	0.155	1	0.86	0.135	0.87	1	0.87
70	0.67	0.67	0.15	0.69	0.59	0.13	0.6	0.69	0.61
95	0.49	0.5	0.15	0.52	0.43	0.13	0.45	0.52	0.45
120	0.39	0.4	0.145	0.42	0.34	0.13	0.37	0.42	0.36
150	0.31	0.32	0.145	0.35	0.28	0.125	0.3	0.35	0.3
185	0.25	0.26	0.145	0.29	0.22	0.125	0.26	0.29	0.25
240	0.195	0.2	0.14	0.24	0.175	0.125	0.21	0.24	0.21
300	0.155	0.16	0.14	0.21	0.14	0.12	0.185	0.21	0.19
400	0.12	0.13	0.14	0.19	0.115	0.12	0.165	0.19	0.18

Note : r = conductor resistance at operating temperature

x = reactance

z = impedance



Rated Voltage



Standard

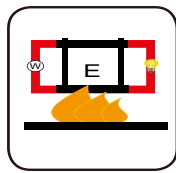

Circuit Integrity
IEC 60331/BS 6387
NF C32-070-2.3(CR1)



Reduced Fire Propagation
NF C32-070-2.2(C1)
IEC60332-3-24/EN50266-2-4



Flame Retardancy
NF C32-070-2.1(C2)
IEC60332-1-2/EN50265-2-1



Low Toxicity
NES 02-713/NF C 20-454



Low Corrosivity
IEC60754-2
EN50267-2-2/3
NF C 32-074



Low Smoke Emission
IEC 61034-1&2
EN 50268-1&2/NF C32-073

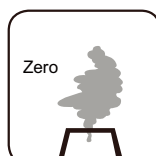

Halogen Free
IEC60754-1
EN50267-2-1

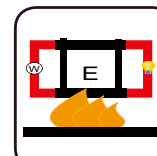

Functional Integrity
DIN 4102-12



300/500V SR Insulated Control Cables (2-4 Cores)

FFX200 05SZ1-U (PH60) (CU/SR/LSZH 300/500V Class 1)

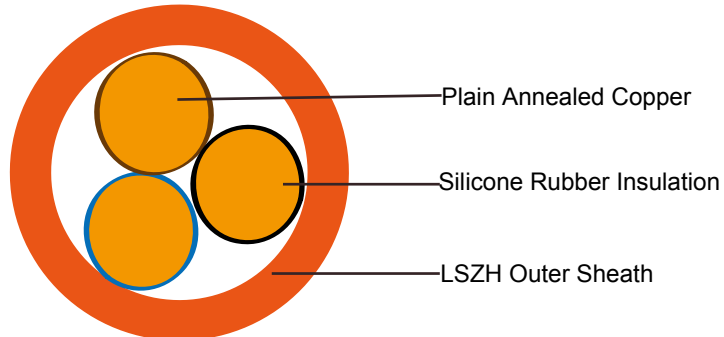
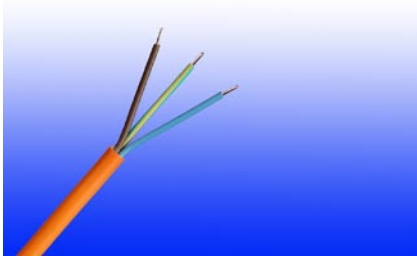

APPLICATION

The cables are designed, for use as control cable for emergency services and fire circuit control.

STANDARDS

Basic design adapted from BS 7629-1

FIRE PERFORMANCE

Circuit Integrity	IEC 60331-21; BS 6387 CWZ; DIN VDE 0472-814(FE180); BS 8434-1 (30mins); BS 5839-1 Clause 26 2d; CEI 20-36/2-1; SS299-1; NBN C 30-004 (cat. F3); NF C32-070-2.3(CR1)
Circuit Integrity with mechanical shock	EN 50200(PH60); CEI 20-36/4-0
Circuit Integrity with mechanical shock & water spray	EN 50200 annex E
System Circuit Integrity	DIN 4102-12, E30 depending on lay system
Flame Retardance (Single Vertical Wire Test)	EN 60332-1-2; IEC 60332-1-2; BS EN 60332-1-2; VDE 0482-332-1 ; NBN C 30-004 (cat. F1); NF C32-070-2.1(C2); CEI 20-35/1-2; EN 50265-2-1*; DIN VDE 0482-265-2-1*
Reduced Fire Propagation (Vertically-mounted bundled wires & cable test)	EN 60332-3-24 (cat. C); IEC 60332-3-24; BS EN 60332-3-24; VDE 0482-332-3; NBN C 30-004 (cat. F2); NF C32-070-2.2(C1); CEI 20-22/3-4; EN 50266-2-4*; DIN VDE 0482-266-2-4
Halogen Free	IEC 60754-1; EN 50267-2-1; DIN VDE 0482-267-2-1; CEI 20-37/2-1 ; BS 6425-1*
No Corrosive Gas Emission	IEC 60754-2; EN 50267-2-2; DIN VDE 0482-267-2-2; CEI 20-37/2-2 ; BS 6425-2*
Minimum Smoke Emission	IEC 61034-1&2; EN 61034 -1&2; DIN VDE 0482-1034-1&2; CEI 20-37/3-1&2; EN 50268-1&2*; BS 7622-1&2*
No Toxic gases	NES 02-713; NF C 20-454

Note: Asterisk * denotes superseded standard.

VOLTAGE RATING

300/500 V

CABLE CONSTRUCTION

Conductors: Plain annealed copper wire, solid according to IEC 60228 class 1.

Insulation: Fire resistant silicone rubber compound type EI2 as per BS 7655-1.1.

Cabling: The cores are cabled together in concentric layers with suitable non-hygroscopic fillers.

Outer Sheath: Thermoplastic LSZH compound type LTS3 as per BS 7655-6.1 (Thermosetting LSZH compound type SW2-SW4 as per BS 7655-2.6 can be offered.). UV resistance, hydrocarbon resistance, oil resistance, anti rodent and anti termite properties can be offered as option.

COLOUR CODE

Insulation Colour as per BS7671

	Without Earth Conductor
2Cores	Brown, Blue
3Cores	Brown, Gray, Black
4Cores	Brown, Gray, Black, Blue

Sheath Colour: Orange (other colors upon request)

PHYSICAL AND THERMAL PROPERTIES

Temperature range during operation (fixed state): -30°C – +90°C

Temperature range during installation (mobile state): -20°C – +50°C

Minimum bending radius: 6 x Overall Diameter

ELECTRICAL PROPERTIES

Dielectric test:	2000 V r.m.s. x 5' (core/core)
Insulation resistance	≥300 MΩ x km (at 20°C)
Short circuit temperature	350°C



CONSTRUCTION PARAMETERS

Cable Code	No. of Core X Cross Section	Nominal Insulation Thickness	Nominal Sheath Thickness	Nominal Overall Diameter	Approx. Weight
	mm ²	mm	mm	mm	kg/km
2 core					
FFX200 05SZ1-U (PH60)	2x1.5	0.7	0.9	7.4	70
FFX200 05SZ1-U (PH60)	2x2.5	0.8	1.0	8.8	105
3 core					
FFX200 05SZ1-U (PH60)	3x1.5	0.7	0.9	7.9	93
FFX200 05SZ1-U (PH60)	3x2.5	0.8	1.0	9.4	141
4 core					
FFX200 05SZ1-U (PH60)	4x1.5	0.7	1.0	8.8	122
FFX200 05SZ1-U (PH60)	4x2.5	0.8	1.1	10.4	183

ELECTRICAL PROPERTIES

Conductor Operating Temperature : 90°C

Ambient Temperature : 30°C

Current-Carrying Capacities (Amp)

Conductor cross-sectional area	Reference Method 4 (enclosed in an conduit insulated wall etc)	Reference Method 3 (enclosed in conduit on a wall or ceiling, or in trunking)		Reference Method 1 (clipped direct)		Reference Method 11 (on a perforated cable tray), or Reference Method 13 (free air)	
	one 3-core cable or one 4-core cable 3-phase a.c.	one 2-core cable singlephase a.c. or d.c.	one 3-core cable or one 4-core cable 3-phase a.c.	one 2-core cable singlephase a.c. or d.c.	one 3-core cable or one 4-core cable 3-phase a.c.	one 2-core cable singlephase a.c. or d.c.	one 3-core cable or one 4-core cable 3-phase a.c.
1	2	3	4	5	6	7	8
mm ²	A	A	A	A	A	A	A
1.5	16.5	22	19.5	24	22	26	23
2.5	22	30	26	33	30	36	32

Voltage Drop (Per Amp Per Meter)

Nominal Cross Section Area	2-core cable d.c.	2 cables, single-phase a.c.	3 or 4 cables, 3-phase a.c.
1	2	3	4
mm ²	mV/A/m	mV/A/m	mV/A/m
1.5	31	31	27
2.5	19	19	16



300/500V

Rated Voltage



BS 7629-1

Standard

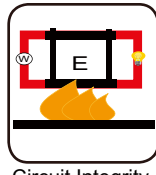

Circuit Integrity
IEC 60331/BS 6387
EN 50200
NF C32-070-2.3(CR1)



Reduced Fire Propagation
NF C32-070-2.2(C1)
IEC60332-3-24/EN50266-2-4



Flame Retardancy
NF C32-070-2.1(C2)
IEC60332-1-2/EN50265-2-1



Low Toxicity
NES 02-713/NF C 20-454



Low Corrosivity
IEC60754-2
EN50267-2-2/3
NF C 32-074



Low Smoke Emission
IEC 61034-1&2
EN 50268-1&2/NF C32-074

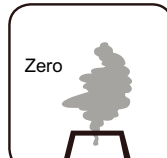

Halogen Free
IEC60754-1
EN50267-2-1

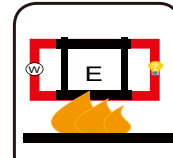

Functional Integrity
DIN 4102-12



300/500V SR Insulated & Overall Screened Control Cables (2-4 Cores & Multicore)

FFX200 05SOZ1-U (PH30/60) (CU/SR/OSCR/LSZH 300/500V Class 1)

FFX200 05SOZ1-R (PH30/60) (CU/SR/OSCR/LSZH 300/500V Class 2)

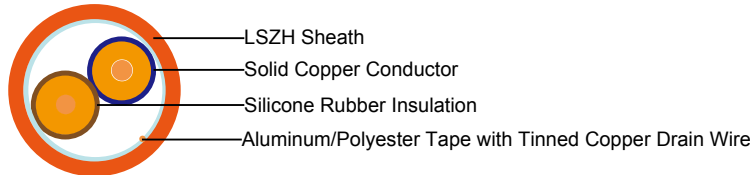
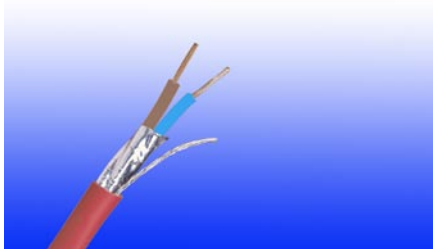

APPLICATION

The cables are primarily intended for use in the following applications:

BS 5266-1 for emergency lighting of premises

BS 5839-1 for fire detection and fire alarm systems in and around building

BS 5839-8 for voice alarm systems

BS 5839-9 for emergency voice communication systems.

STANDARDS

Basic design to BS7629-1

FIRE PERFORMANCE

Circuit Integrity	IEC 60331-21; BS 6387 CWZ; DIN VDE 0472-814(FE180); BS 8434-1 (30mins); BS 5839-1 Clause 26 2d; CEI 20-36/2-1; SS299-1; NBN C 30-004 (cat. F3); NF C32-070-2.3(CR1)
Circuit Integrity with mechanical shock	EN 50200(PH30/60); CEI 20-36/4-0
Circuit Integrity with mechanical shock & water spray	EN 50200 annex E
System Circuit Integrity	DIN 4102-12, E30 depending on lay system
Flame Retardance (Single Vertical Wire Test)	EN 60332-1-2; IEC 60332-1-2; BS EN 60332-1-2; VDE 0482-332-1 ; NBN C 30-004 (cat. F1); NF C32-070-2.1(C2); CEI 20-35/1-2; EN 50265-2-1*; DIN VDE 0482-265-2-1*
Reduced Fire Propagation (Vertically-mounted bundled wires & cable test)	EN 60332-3-24 (cat. C); IEC 60332-3-24; BS EN 60332-3-24; VDE 0482-332-3; NBN C 30-004 (cat. F2); NF C32-070-2.2(C1); CEI 20-22/3-4; EN 50266-2-4*; DIN VDE 0482-266-2-4
Halogen Free	IEC 60754-1; EN 50267-2-1; DIN VDE 0482-267-2-1; CEI 20-37/2-1 ; BS 6425-1*
No Corrosive Gas Emission	IEC 60754-2; EN 50267-2-2; DIN VDE 0482-267-2-2; CEI 20-37/2-2 ; BS 6425-2*

Minimum Smoke Emission	IEC 61034-1&2; EN 61034 -1&2; DIN VDE 0482-1034-1&2; CEI 20-37/3-1&2; EN 50268-1&2*; BS 7622-1&2*
No Toxic gases	NES 02-713; NF C 20-454

Note: Asterisk * denotes superseded standard.

VOLTAGE RATING

300/500 V

CABLE CONSTRUCTION

Conductors: Plain annealed copper wire, solid according to IEC 60228 class 1, stranded according to IEC 60228 class 2.

Insulation: Fire resistant silicone rubber compound type EI2 as per BS 7655-1.1.

Cabling: The cores are cabled together in concentric layers with suitable non-hygroscopic fillers.

Overall Screen: Aluminum/polyester tape with tinned copper drain wire.

Circuit Protective Conductor or Drain Wire: Uninsulated tinned copper conductor of the same section and class as the insulated conductors in the 2-, 3-and 4-core cables. Drain wire of 0.5mm² tinned copper conductor is provided in cables of more than 4 conductors.

Outer Sheath: Thermoplastic LSZH compound type LTS3 as per BS 7655-6.1 (Thermosetting LSZH compound type SW2-SW4 as per BS 7655-2.6 can be offered.). UV resistance, hydrocarbon resistance, oil resistance, anti rodent and anti termite properties can be offered as option.

COLOUR CODE

Insulation Colour:

	Without Earth Conductor
2Cores	Brown, Blue
3Cores	Brown, Gray, Black
4Cores	Brown, Gray, Black, Blue
7Cores	Centre: Brown, 1st layer: Brown -Black -4 Cores White
12Cores	Centre: Brown, Black -White 1st layer: Brown -Black -7 Cores White
19Cores	Centre: Brown , 1st layer: Brown -Black -4 Cores White 2nd layer: Brown -black -10 Cores White

Sheath Colour: Orange (other colors upon request)

PHYSICAL AND THERMAL PROPERTIES

Temperature range during operation (fixed state): -30°C – +90°C

Temperature range during installation (mobile state): -20°C – +50°C

Minimum bending radius: 6 x Overall Diameter

ELECTRICAL PROPERTIES

Dielectric test:	2000 V r.m.s. x 5' (core/core)
Insulation resistance	≥300 MΩ x km (at 20°C)
Short circuit temperature	350°C



CONSTRUCTION PARAMETERS

Cable Code	No. of Core X Cross Section	Nominal Insulation Thickness	Nominal Sheath Thickness	Nominal Overall Diameter	Approx. Weight
	mm ²	mm	mm	mm	kg/km
2 core					
FFX200 05SOZ1-U (PH30/60)	2x1.0	0.6	0.9	7.1	80
FFX200 05SOZ1-U (PH30/60)	2x1.5	0.7	0.9	8.0	95
FFX200 05SOZ1-U (PH30/60)	2x2.5	0.8	1.0	9.4	135
FFX200 05SOZ1-R (PH30/60)	2x1.5	0.7	0.9	8.4	106
FFX200 05SOZ1-R (PH30/60)	2x2.5	0.8	1.0	9.9	145
FFX200 05SOZ1-R (PH30/60)	2x4.0	0.8	1.1	11.5	210
3 core					
FFX200 05SOZ1-U (PH30/60)	3x1.0	0.6	0.9	8.0	95
FFX200 05SOZ1-U (PH30/60)	3x1.5	0.7	0.9	8.5	115
FFX200 05SOZ1-U (PH30/60)	3x2.5	0.8	1.0	10.0	170
FFX200 05SOZ1-R (PH30/60)	3x1.5	0.7	0.9	8.9	134
FFX200 05SOZ1-R (PH30/60)	3x2.5	0.8	1.0	10.3	180
FFX200 05SOZ1-R (PH30/60)	3x4.0	0.8	1.1	12.2	260
4 core					
FFX200 05SOZ1-U (PH30/60)	4x1.0	0.6	1.0	8.3	115
FFX200 05SOZ1-U (PH30/60)	4x1.5	0.7	1.0	9.4	150
FFX200 05SOZ1-U (PH30/60)	4x2.5	0.8	1.1	11.0	210
FFX200 05SOZ1-R (PH30/60)	4x1.5	0.7	1.0	9.8	166
FFX200 05SOZ1-R (PH30/60)	4x2.5	0.8	1.1	11.8	250
FFX200 05SOZ1-R (PH30/60)	4x4.0	0.8	1.2	13.5	330
7 Core					
FFX200 05SOZ1-U (PH30/60)	7x1.0	0.6	1.0	10.0	165
FFX200 05SOZ1-U (PH30/60)	7x1.5	0.7	1.1	11.3	225
12 core					
FFX200 05SOZ1-U (PH30/60)	12x1.0	0.6	1.1	12.5	255
FFX200 05SOZ1-U (PH30/60)	12x1.5	0.7	1.2	14.5	350
19 core					
FFX200 05SOZ1-U (PH30/60)	19x1.0	0.6	1.2	15.0	380
FFX200 05SOZ1-U (PH30/60)	19x1.5	0.7	1.3	17.0	520

ELECTRICAL PROPERTIES

Conductor Operating Temperature : 90°C

Ambient Temperature : 30°C

Current-Carrying Capacities (Amp)

Nominal Cross Section Area	Reference Method 4 (enclosed in an conduit insulated wall etc)	Reference Method 3 (enclosed in conduit on a wall or ceiling, or in trunking)		Reference Method 1 (clipped direct)		Reference Method 11 (on a perforated cable tray), or Reference Method 13 (free air)	
	one 3-core cable or one 4-core cable 3-phase a.c.	one 2-core cable single phase a.c. or d.c.	one 3-core cable or one 4-core cable 3-phase a.c.	one 2-core cable single phase a.c. or d.c.	one 3-core cable or one 4-core cable 3-phase a.c.	one 2-core	one 3-core
						cable single phase	cable or
						a.c. or	4-core cable
d.c.	3-phase a.c.						
1	2	3	4	5	6	7	8
mm ²	A	A	A	A	A	A	A
1.5	16.5	22	19.5	24	22	26	23
2.5	22	30	26	33	30	36	32
4	30	40	35	45	40	49	42





Voltage Drop (Per Amp Per Meter)

Nominal Cross Section Area	2-core cable d.c.	2-core cable single-phase a.c	3-core or 4-core cable 3-phase a.c.
1	2	3	4
mm ²	mV/A/m	mV/A/m	mV/A/m
1.5	31	31	27
2.5	19	19	16
4	12	12	10



300/500V

Rated Voltage



BS 7629-1

Standard

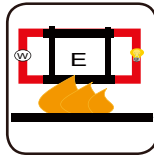

Circuit Integrity
IEC 60331/BS 6387
EN 50200
NF C32-070-2.3(CR1)



Reduced Fire Propagation
NF C32-070-2.2(C1)
IEC60332-3-24/EN50266-2-4



Flame Retardancy
NF C32-070-2.1(C2)
IEC60332-1-2/EN50265-2-1



Low Toxicity
NES 02-713/NF C 20-454



Low Corrosivity
IEC60754-2
EN50267-2-2/3
NF C 32-074



Low Smoke Emission
IEC 61034-1&2
EN 50268-1&2/NF C32-073

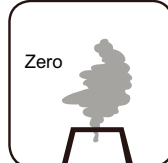

Zero
Halogen Free
IEC60754-1
EN50267-2-1

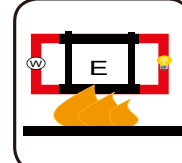

Functional Integrity
DIN 4102-12

300/500V Mica+SR Insulated & Overall Screened Control Cables (2-4 Cores & Multicore)

FFX200E 05mSOZ1-U (PH120) (CU/MGT+SR/OSCR/LSZH 300/500V Class 1)
 FFX200E 05mSOZ1-R (PH120) (CU/MGT+SR/OSCR/LSZH 300/500V Class 2)

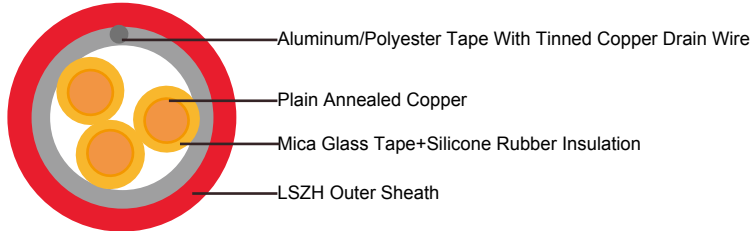
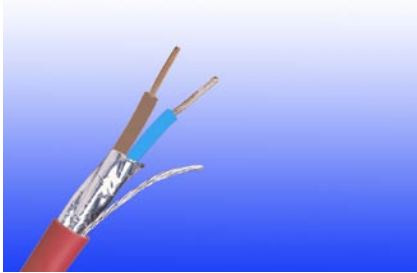

APPLICATION

The cables are primarily intended for use in the following applications:

- BS 5266-1 for emergency lighting of premises
- BS 5839-1 for fire detection and fire alarm systems in and around building
- BS 5839-8 for voice alarm systems
- BS 5839-9 for emergency voice communication systems.

STANDARDS

Basic design to BS 7629-1

FIRE PERFORMANCE

Circuit Integrity	IEC 60331-21; BS 6387 CWZ; DIN VDE 0472-814(FE180); BS 8434-2 (120mins); BS 5839-1 Clause 26 2e; CEI 20-36/2-1; SS299-1; NBN C 30-004 (cat. F3); NF C32-070-2.3(CR1)
Circuit Integrity with mechanical shock	EN 50200(PH120); CEI 20-36/4-0
Circuit Integrity with mechanical shock & water spray	EN 50200 annex E
System Circuit Integrity	DIN 4102-12, E30 depending on lay system
Flame Retardance (Single Vertical Wire Test)	EN 60332-1-2; IEC 60332-1-2; BS EN 60332-1-2; VDE 0482-332-1 ; NBN C 30-004 (cat. F1); NF C32-070-2.1(C2); CEI 20-35/1-2; EN 50265-2-1*; DIN VDE 0482-265-2-1*
Reduced Fire Propagation (Vertically-mounted bundled wires & cable test)	EN 60332-3-24 (cat. C); IEC 60332-3-24; BS EN 60332-3-24; VDE 0482-332-3; NBN C 30-004 (cat. F2); NF C32-070-2.2(C1); CEI 20-22/3-4; EN 50266-2-4*; DIN VDE 0482-266-2-4
Halogen Free	IEC 60754-1; EN 50267-2-1; DIN VDE 0482-267-2-1; CEI 20-37/2-1 ; BS 6425-1*
No Corrosive Gas Emission	IEC 60754-2; EN 50267-2-2; DIN VDE 0482-267-2-2; CEI 20-37/2-2 ; BS 6425-2*
Minimum Smoke Emission	IEC 61034-1&2; EN 61034 -1&2; DIN VDE 0482-1034-1&2; CEI 20-37/3-1&2; EN 50268-1&2*; BS 7622-1&2*



No Toxic gases	NES 02-713; NF C 20-454
----------------	-------------------------

Note: Asterisk * denotes superseded standard.

VOLTAGE RATING

300/500 V

CABLE CONSTRUCTION

Conductors: Plain annealed copper wire, solid according to IEC 60228 class 1, stranded according to IEC 60228 class 2.

Insulation: Mica glass fire resistant tape covered by fire resistant silicone rubber compound type EI2 as per BS 7655-1.1.

Cabling: The cores are cabled together in concentric layers with suitable non-hygroscopic fillers.

Overall Screen: Aluminum/polyester tape with tinned copper drain wire.

Circuit Protective Conductor: Uninsulated tinned copper conductor of the same section and class as the insulated conductors in the 2-, 3- and 4-core cables. Drain wire of 0.5mm² tinned copper conductor is provided in cables of more than 4 conductors.

Outer Sheath: Thermoplastic LSZH compound type LTS3 as per BS 7655-6.1 (Thermosetting LSZH compound type SW2-SW4 as per BS 7655-2.6 can be offered.). UV resistance, hydrocarbon resistance, oil resistance, anti rodent and anti termite properties can be offered as option.

COLOUR CODE

Insulation Colour:

	Without Earth Conductor
2Cores	Brown, Blue
3Cores	Brown, Gray, Black
4Cores	Brown, Gray, Black, Blue
7Cores	Centre: Brown, 1st layer: Brown -Black -4 Cores White
12Cores	Centre: Brown, Black -White 1st layer: Brown -Black -7 Cores White
19Cores	Centre: Brown , 1st layer: Brown -Black -4 Cores White 2nd layer: Brown -black -10 Cores White

Sheath Colour: Colour red or white (other colours on request)

PHYSICAL AND THERMAL PROPERTIES

Temperature range during operation (fixed state): -30°C – +90°C

Temperature range during installation (mobile state): -20°C – +50°C

Minimum bending radius: 7.5 x Overall Diameter

ELECTRICAL PROPERTIES

Dielectric test:	2000 V r.m.s. x 5' (core/core)
Insulation resistance	≥300 MΩ x km (at 20°C)
Short circuit temperature	350°C

CONSTRUCTION PARAMETERS

Cable Code	No. of Core X Cross Section	Nominal Insulation Thickness	Nominal Sheath Thickness	Nominal Overall Diameter	Approx. Weight
	mm ²	mm	mm	mm	kg/km
2 core,					
FFX200E 05mSOZ1-U(PH120)	2x1.0	0.6	0.9	7.9	85
FFX200E 05mSOZ1-U(PH120)	2x1.5	0.7	0.9	8.8	105
FFX200E 05mSOZ1-U(PH120)	2x2.5	0.8	1.0	10.2	150
FFX200E 05mSOZ1-R(PH120)	2x1.5	0.7	0.9	9.2	110
FFX200E 05mSOZ1-R(PH120)	2x2.5	0.8	1.0	10.3	155
FFX200E 05mSOZ1-R(PH120)	2x4.0	0.8	1.1	12.2	220
3 core					
FFX200E 05mSOZ1-U(PH120)	3x1.0	0.6	0.9	8.4	105
FFX200E 05mSOZ1-U(PH120)	3x1.5	0.7	0.9	9.3	130
FFX200E 05mSOZ1-U(PH120)	3x2.5	0.8	1.0	10.8	190
FFX200E 05mSOZ1-R(PH120)	3x1.5	0.7	0.9	9.4	135
FFX200E 05mSOZ1-R(PH120)	3x2.5	0.8	1.0	10.9	190
FFX200E 05mSOZ1-R(PH120)	3x4.0	0.8	1.1	13.0	280
4 core					
FFX200E 05mSOZ1-U(PH120)	4x1.0	0.6	1.0	9.3	125
FFX200E 05mSOZ1-U(PH120)	4x1.5	0.7	1.0	10.3	165
FFX200EE 05mSOZ1-U(PH120)	4x2.5	0.8	1.1	12.0	240
FFX200E 05mSOZ1-R(PH120)	4x1.5	0.7	1.0	10.5	170
FFX200E 05mSOZ1-R(PH120)	4x2.5	0.8	1.1	12.1	250
FFX200E 05mSOZ1-R(PH120)	4x4.0	0.8	1.2	14.4	350
7 core					
FFX200E 05mSOZ1-U(PH120)	7x1.0	0.6	1.0	10.5	175
FFX200E 05mSOZ1-U(PH120)	7x1.5	0.7	1.1	12.1	230
12 core					
FFX200E 05mSOZ1-U(PH120)	12x1.0	0.6	1.1	14.5	300
FFX200E 05mSOZ1-U(PH120)	12x1.5	0.7	1.2	16.0	380
19 core					
FFX200E 05mSOZ1-U(PH120)	19x1.0	0.6	1.2	17.5	470
FFX200E 05mSOZ1-U(PH120)	19x1.5	0.7	1.3	17.5	470



ELECTRICAL PROPERTIES

Conductor Operating Temperature : 90°C

Ambient Temperature : 30°C

Current-Carrying Capacities (Amp)

Conductor cross-sectional area	Reference Method 4 (enclosed in an conduit insulated wall etc)	Reference Method 3 (enclosed in conduit on a wall or ceiling, or in trunking)		Reference Method 1 (clipped direct)		Reference Method 11 (on a perforated cable tray), or Reference Method 13 (free air)	
	one 3-core cable or one 4-core cable 3-phase a.c.	one 2-core cable singlephase a.c. or d.c.	one 3-core cable or one 4-core cable 3-phase a.c.	one 2-core cable singlephase a.c. or d.c.	one 3-core cable or one 4-core cable 3-phase a.c.	one 2-core cable singlephase a.c. or d.c.	one 3-core cable or one 4-core cable 3-phase a.c.
1	2	3	4	5	6	7	8
mm ²	A	A	A	A	A	A	A
1.5	16.5	22	19.5	24	22	26	23
2.5	22	30	26	33	30	36	32
4	30	40	35	45	40	49	42

Voltage Drop (Per Amp Per Meter)

Nominal Cross Section Area	2-core cable d.c.	2-core cable single-phase a.c	3-core or 4-core cable 3-phase a.c.
1	2	3	4
mm ²	mV/A/m	mV/A/m	mV/A/m
1.5	31	31	27
2.5	19	19	16
4	12	12	10

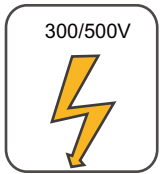

300/500V

Rated Voltage



BS 7629-1

Standard

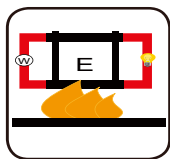

Circuit Integrity
IEC 60331/BS 6387
EN 50200
NF C32-070-2.3(CR1)



Reduced Fire Propagation
NF C32-070-2.2(C1)
IEC60332-3-24/EN50266-2-4



Flame Retardancy
NF C32-070-2.1(C2)
IEC60332-1-2/EN50265-2-1



Low Toxicity
NES 02-713/NF C 20-454



Low Corrosivity
IEC60754-2
EN50267-2-2/3
NF C 32-074



Low Smoke Emission
IEC 61034-1&2
EN 50268-1&2/NF C32-073

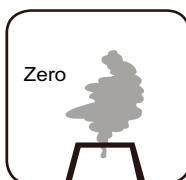

Halogen Free
IEC60754-1
EN50267-2-1

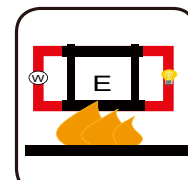

Functional Integrity
DIN 4102-12

450/750V SR Insulated Control Cables (2-5 Cores)

FFX200 07SZ1-R (PH60) (CU/SR/LSZH 450/750V Class 2)

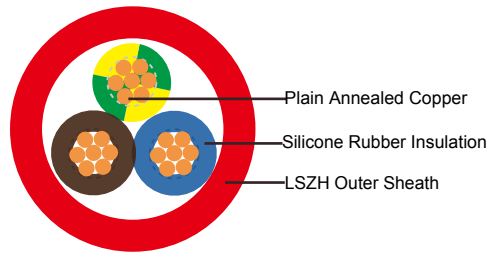
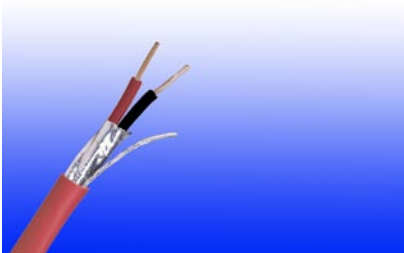

APPLICATION

The cables are designed, manufactured and tested for general application in power supply and signal wiring, for emergency circuit and fire circuit control.

STANDARDS

Basic design adapted from BS 7629-1

FIRE PERFORMANCE

Circuit Integrity	IEC 60331-21; BS 6387 CWZ; DIN VDE 0472-814(FE180); BS 8434-1 (30mins); BS 5839-1 Clause 26 2d; CEI 20-36/2-1; SS299-1; NBN C 30-004 (cat. F3); NF C32-070-2.3(CR1)
Circuit Integrity with mechanical shock	EN 50200(PH60); CEI 20-36/4-0
Circuit Integrity with mechanical shock & water spray	EN 50200 annex E
System Circuit Integrity	DIN 4102-12, E30 depending on lay system
Flame Retardance (Single Vertical Wire Test)	EN 60332-1-2; IEC 60332-1-2; BS EN 60332-1-2; VDE 0482-332-1 ; NBN C 30-004 (cat. F1); NF C32-070-2.1(C2); CEI 20-35/1-2; EN 50265-2-1*; DIN VDE 0482-265-2-1*
Reduced Fire Propagation (Vertically-mounted bundled wires & cable test)	EN 60332-3-24 (cat. C); IEC 60332-3-24; BS EN 60332-3-24; VDE 0482-332-3; NBN C 30-004 (cat. F2); NF C32-070-2.2(C1); CEI 20-22/3-4; EN 50266-2-4*; DIN VDE 0482-266-2-4
Halogen Free	IEC 60754-1; EN 50267-2-1; DIN VDE 0482-267-2-1; CEI 20-37/2-1 ; BS 6425-1*
No Corrosive Gas Emission	IEC 60754-2; EN 50267-2-2; DIN VDE 0482-267-2-2; CEI 20-37/2-2 ; BS 6425-2*
Minimum Smoke Emission	IEC 61034-1&2; EN 61034 -1&2; DIN VDE 0482-1034-1&2; CEI 20-37/3-1&2; EN 50268-1&2*; BS 7622-1&2*
No Toxic gases	NES 02-713; NF C 20-454

Note: Asterisk * denotes superseded standard.



VOLTAGE RATING

450/750 V

CABLE CONSTRUCTION

Conductors: Plain annealed copper wire, stranded according to IEC 60228 class 2.

Insulation: Fire resistant silicone rubber compound type EI2 as per BS 7655-1.1.

Cabling: The cores are cabled together in concentric layers with suitable non-hygroscopic fillers.

Outer Sheath: Thermoplastic LSZH compound type LTS3 as per BS 7655-6.1 (Thermosetting LSZH compound type SW2-SW4 as per BS 7655-2.6 can be offered.). UV resistance, hydrocarbon resistance, oil resistance, anti rodent and anti termite properties can be offered as option.

COLOUR CODE

Insulation Colour:

	Without Earth Conductor
2Cores	Brown, Blue
3Cores	Brown, Gray, Black
4Cores	Brown, Gray, Black, Blue
5Cores	Brown, Gray, Black, Blue, Black

Sheath Colour: Colour red (other colours on request)

PHYSICAL AND THERMAL PROPERTIES

Temperature range during operation (fixed state): -30°C – +90°C

Temperature range during installation (mobile state): -20°C – +50°C

Minimum bending radius: 7.5 x Overall Diameter

ELECTRICAL PROPERTIES

Dielectric test:	2500 V r.m.s. x 5' (core/core)
Insulation resistance	≥300 MΩ x km (at 20°C)
Short circuit temperature	350°C

CONSTRUCTION PARAMETERS

Cable Code	No. of Core X Cross Section	Nominal Insulation Thickness	Nominal Sheath Thickness	Nominal Overall Diameter	Approx. Weight
	mm ²	mm	mm	mm	kg/km
2 core					
FFX200 07SZ1-R (PH60)	2x1.5	0.8	1.0	7,8	96
FFX200 07SZ1-R (PH60)	2x2.5	0.9	1.1	9,2	138
FFX200 07SZ1-R (PH60)	2x4.0	0.9	1.2	10,5	189

3 core					
FFX200 07SZ1-R (PH60)	3x1.5	0.8	1.0	8,3	116
FFX200 07SZ1-R (PH60)	3x2.5	0.9	1.1	9,8	169
FFX200 07SZ1-R (PH60)	3x4.0	0.9	1.2	11,6	246
4 core					
FFX200 07SZ1-R (PH60)	4x1.5	0.8	1.1	9,3	147
FFX200 07SZ1-R (PH60)	4x2.5	0.9	1.2	11,3	222
FFX200 07SZ1-R (PH60)	4x4.0	0.9	1.3	12,5	299
5 core					
FFX200 07SZ1-R (PH60)	5x1.5	0.8	1.1	10,5	180
FFX200 07SZ1-R (PH60)	5x2.5	0.9	1.2	12,3	259
FFX200 07SZ1-R (PH60)	5x4.0	0.9	1.3	14,0	359

ELECTRICAL PROPERTIES

Conductor Operating Temperature : 90°C

Ambient Temperature : 30°C

Current-Carrying Capacities (Amp)

Conductor cross-sectional area	Reference Method 4 (enclosed in an conduit insulated wall etc)	Reference Method 3 (enclosed in conduit on a wall or ceiling, or in trunking)		Reference Method 1 (clipped direct)		Reference Method 11 (on a perforated cable tray), or Reference Method 13 (free air)	
	one 3-core cable or one 4-core cable 3-phase a.c.	one 2-core cable singlephase a.c. or d.c.	one 3-core cable or one 4-core cable 3-phase a.c.	one 2-core cable singlephase a.c. or d.c.	one 3-core cable or one 4-core cable 3-phase a.c.	one 2-core cable singlephase a.c. or d.c.	one 3-core cable or one 4-core cable 3-phase a.c.
1	2	3	4	5	6	7	8
mm ²	A	A	A	A	A	A	A
1.5	16.5	22	19.5	24	22	26	23
2.5	22	30	26	33	30	36	32
4	30	40	35	45	40	49	42



Voltage Drop (Per Amp Per Meter)

Nominal Cross Section Area	2-core cable d.c.	2-core cable single-phase a.c.	3-core or 4-core cable 3-phase a.c.
1	2	3	4
mm ²	mV/A/m	mV/A/m	mV/A/m
1.5	31	31	27
2.5	19	19	16
4	12	12	10



450/750V

Rated Voltage



BS 7629-1

Standard

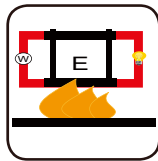

Circuit Integrity
IEC 60331/BS 6387
EN 50200
NF C32-070-2.3(CR1)



Reduced Fire Propagation
NF C32-070-2.2(C1)
IEC60332-3-24/EN50266-2-4



Flame Retardancy
NF C32-070-2.1(C2)
IEC60332-1-2/EN50265-2-1



Low Toxicity
NES 02-713/NF C 20-454

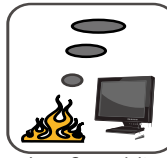

Low Corrosivity
IEC60754-2
EN50267-2-2/3
NF C 32-074



Low Smoke Emission
IEC 61034-1&2
EN 50268-1&2/NF C32-073

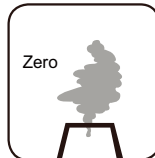

Halogen Free
IEC60754-1
EN50267-2-1

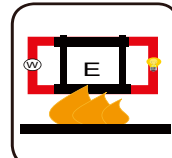

Functional Integrity
DIN 4102-12

450/750V SR Insulated & Overall Screened Control Cables (1-4 Cores & Multicore)

FFX200 07SOZ1-F (PH30/60)(CU/SR/OSCR/LSZH 450/750V Class 5)

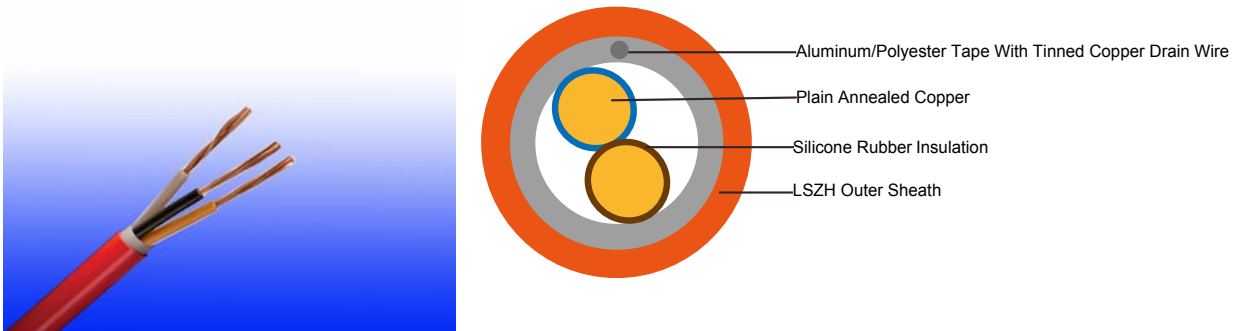

APPLICATION

The cables are designed, manufactured and tested for general application in power and signal wiring, for emergency circuit and fire circuit control where high rejection to electrostatic noise is needed.

STANDARDS

Basic design adapted from BS 7629-1

FIRE PERFORMANCE

Circuit Integrity	IEC 60331-21; BS 6387 CWZ; DIN VDE 0472-814(FE180); BS 8434-1 (30mins); BS 5839-1 Clause 26 2d; CEI 20-36/2-1; SS299-1; NBN C 30-004 (cat. F3); NF C32-070-2.3(CR1)
Circuit Integrity with mechanical shock	EN 50200(PH30/60); CEI 20-36/4-0
Circuit Integrity with mechanical shock & water spray	EN 50200 annex E
System Circuit Integrity	DIN 4102-12, E30 depending on lay system
Flame Retardance (Single Vertical Wire Test)	EN 60332-1-2; IEC 60332-1-2; BS EN 60332-1-2; VDE 0482-332-1 ; NBN C 30-004 (cat. F1); NF C32-070-2.1(C2); CEI 20-35/1-2; EN 50265-2-1*; DIN VDE 0482-265-2-1*
Reduced Fire Propagation (Vertically-mounted bundled wires & cable test)	EN 60332-3-24 (cat. C); IEC 60332-3-24; BS EN 60332-3-24; VDE 0482-332-3; NBN C 30-004 (cat. F2); NF C32-070-2.2(C1); CEI 20-22/3-4; EN 50266-2-4*; DIN VDE 0482-266-2-4
Halogen Free	IEC 60754-1; EN 50267-2-1; DIN VDE 0482-267-2-1; CEI 20-37/2-1 ; BS 6425-1*
No Corrosive Gas Emission	IEC 60754-2; EN 50267-2-2; DIN VDE 0482-267-2-2; CEI 20-37/2-2 ; BS 6425-2*
Minimum Smoke Emission	IEC 61034-1&2; EN 61034 -1&2; DIN VDE 0482-1034-1&2; CEI 20-37/3-1&2; EN 50268-1&2*; BS 7622-1&2*
No Toxic gases	NES 02-713; NF C 20-454

Note: Asterisk * denotes superseded standard.



VOLTAGE RATING

450/750 V

CABLE CONSTRUCTION

Conductors: Plain annealed copper wire, flexible according to IEC 60228 class 5.

Insulation: Fire resistant silicone rubber compound type EI2 as per BS 7655-1.1.

Cabling: The cores are cabled together in concentric layers with suitable non-hygroscopic fillers.

Overall Screen: Aluminum/polyester tape with tinned copper drain wire.

Outer Sheath: Thermoplastic LSZH compound type LTS3 as per BS 7655-6.1 Thermosetting LSZH compound type SW2-SW4 as per BS 7655-2.6 can be offered.). UV resistance, hydrocarbon resistance, oil resistance, anti rodent and anti termite properties can be offered as option.

COLOUR CODE

Insulation Colour:

	Without Earth Conductor
2Cores	Brown, Blue
3Cores	Brown, Gray, Black
4Cores	Brown, Gray, Black, Blue
7Cores	Centre: Brown, 1st layer: Brown -Black -4 Cores White
12Cores	Centre: Brown, Black -White 1st layer: Brown -Black -7 Cores White
19Cores	Centre: Brown , 1st layer: Brown -Black -4 Cores White 2nd layer: Brown -black -10 Cores White

Sheath Colour: Colour red (other colours on request)

PHYSICAL AND THERMAL PROPERTIES

Temperature range during operation (fixed state): -30°C – +90°C

Temperature range during installation (mobile state): -20°C – +50°C

Minimum bending radius: 7.5 x Overall Diameter

ELECTRICAL PROPERTIES

Dielectric test:	2500 V r.m.s. x 5' (core/core)
Insulation Resistance	≥300 MΩ x km (at 20°C)
Short circuit Temperature	350°C

CONSTRUCTION PARAMETERS

Cable Code	No. of Core X Cross Section	Nominal Insulation Thickness	Nominal Sheath Thickness	Nominal Overall Diameter	Approx. Weight
	mm ²	mm	mm	mm	kg/km
2 core					
FFX200 07SOZ1-F(PH30/60)	2x0.75	0.7	0.9	7,6	69
FFX200 07SOZ1-F(PH30/60)	2x1.0	0.7	1.0	8,0	78
FFX200 07SOZ1-F(PH30/60)	2x1.5	0.8	1.0	8,3	88
FFX200 07SOZ1-F(PH30/60)	2x2.5	0.9	1.1	9,8	123
3 core					
FFX200 07SOZ1-F(PH30/60)	3x0.75	0.7	0.9	8,0	84
FFX200 07SOZ1-F(PH30/60)	3x1.0	0.7	1.0	8,2	86
FFX200 07SOZ1-F(PH30/60)	3x1.5	0.8	1.0	8,8	112
FFX200 07SOZ1-F(PH30/60)	3x2.5	0.9	1.1	10,4	159
4 core					
FFX200 07SOZ1-F(PH30/60)	4x0.75	0.7	1.0	8,7	103
FFX200 07SOZ1-F(PH30/60)	4x1.0	0.7	1.1	8,9	110
FFX200 07SOZ1-F(PH30/60)	4x1.5	0.8	1.1	9,8	141
FFX200 07SOZ1-F(PH30/60)	4x2.5	0.9	1.2	11,4	196
7 core					
FFX200 07SOZ1-F(PH30/60)	7x1.0	0.7	1.1	10,8	176
FFX200 07SOZ1-F(PH30/60)	7x1.5	0.8	1.2	11,7	218
FFX200 07SOZ1-F(PH30/60)	7x2.5	0.9	1.3	13,4	305
12 core					
FFX200 07SOZ1-F(PH30/60)	12x1.0	0.7	1.2	13,9	275
FFX200 07SOZ1-F(PH30/60)	12x1.5	0.8	1.3	15,3	352
FFX200 07SOZ1-F(PH30/60)	12x2.5	0.9	1.5	17,9	505
19 core					
FFX200 07SOZ1-F(PH30/60)	19x1.0	0.7	1.4	16,4	408
FFX200 07SOZ1-F(PH30/60)	19x1.5	0.8	1.5	18,2	535
FFX200 07SOZ1-F(PH30/60)	19x2.5	0.9	1.6	21,1	760

ELECTRICAL PROPERTIES

Conductor Operating Temperature : 90°C

Ambient Temperature : 30°C



Current-Carrying Capacities (Amp)

Conductor cross-sectional area	Reference Method 4 (enclosed in an conduit insulated wall etc)	Reference Method 3 (enclosed in conduit on a wall or ceiling, or in trunking)		Reference Method 1 (clipped direct)		Reference Method 11 (on a perforated cable tray), or Reference Method 13 (free air)	
	one 3-core cable or one 4-core cable 3-phase a.c.	one 2-core cable singlephase a.c. or d.c.	one 3-core cable or one 4-core cable 3-phase a.c.	one 2-core cable singlephase a.c. or d.c.	one 3-core cable or one 4-core cable 3-phase a.c.	one 2-core cable singlephase a.c. or d.c.	one 3-core cable or one 4-core cable 3-phase a.c.
1	2	3	4	5	6	7	8
mm ²	A	A	A	A	A	A	A
1.5	16.5	22	19.5	24	22	26	23
2.5	22	30	26	33	30	36	32
4	30	40	35	45	40	49	42

Voltage Drop (Per Amp Per Meter)

Nominal Cross Section Area	2-core cable d.c.	2-core cable single-phase a.c.	3-core or 4-core cable 3-phase a.c.
1	2	3	4
mm ²	mV/A/m	mV/A/m	mV/A/m
1.5	31	31	27
2.5	19	19	16
4	12	12	10



450/750V

Rated Voltage



BS 7629-1

Standard

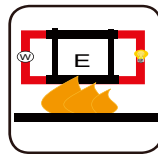

Circuit Integrity
IEC 60331/BS 6387
EN 50200
NF C32-070-2.3(CR1)



Reduced Fire Propagation
NF C32-070-2.2(C1)

IEC60332-3-24/EN50266-2-4



Flame Retardancy
NF C32-070-2.1(C2)

IEC60332-1-2/EN50265-2-1



Low Toxicity
NES 02-713/NF C 20-454



Low Corrosivity
IEC60754-2
EN50267-2-2/3
NF C 32-074



Low Smoke Emission
IEC 61034-1&2
EN 50268-1&2/NF C32-073

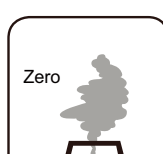

Zero

Halogen Free
IEC60754-1
EN50267-2-1

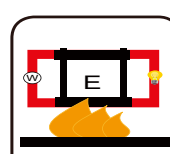

Functional Integrity
DIN 4102-12

600/1000V SR Insulated Flexibles Control Cables (2-4 Cores & Multicore)

FFX400 1SZ1-R(PH60)(CU/SR/LSZH 600/1000V Class 2)

FFX400 1SZ1-F(PH60)(CU/SR/LSZH 600/1000V Class 5)

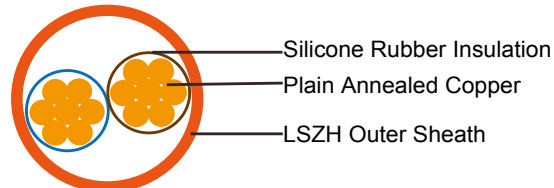
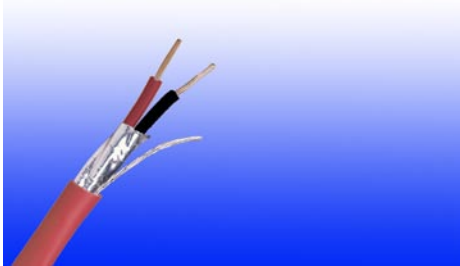

APPLICATION

The cables are designed for power supply and signals transmission, indoor or outdoor even wet environment. They are designed for fixed laying in free air, in pipe or conduit, on masonry and metal structures or suspended in places where in case of fire people are exposed to serious risks for emission of smoke, toxic and corrosive gases and where you want to avoid damage to facilities, equipment, goods. They are primarily intended for feeding of: emergency exits, alarm signals, warning of smoke or gas, escalators.

STANDARDS

Basic design adapted from BS 7629-1

FIRE PERFORMANCE

Circuit Integrity	IEC 60331-21; BS 6387 CWZ; DIN VDE 0472-814(FE180); BS 8434-1 (30mins); BS 5839-1 Clause 26 2d; CEI 20-36/2-1; SS299-1; NBN C 30-004 (cat. F3); NF C32-070-2.3(CR1)
Circuit Integrity with mechanical shock	EN 50200(PH60); CEI 20-36/4-0
Circuit Integrity with mechanical shock & water spray	EN 50200 annex E
System Circuit Integrity	DIN 4102-12, E30 depending on lay system
Flame Retardance (Single Vertical Wire Test)	EN 60332-1-2; IEC 60332-1-2; BS EN 60332-1-2; VDE 0482-332-1 ; NBN C 30-004 (cat. F1); NF C32-070-2.1(C2); CEI 20-35/1-2; EN 50265-2-1*; DIN VDE 0482-265-2-1*
Reduced Fire Propagation (Vertically-mounted bundled wires & cable test)	EN 60332-3-24 (cat. C); IEC 60332-3-24; BS EN 60332-3-24; VDE 0482-332-3; NBN C 30-004 (cat. F2); NF C32-070-2.2(C1); CEI 20-22/3-4; EN 50266-2-4*; DIN VDE 0482-266-2-4
Halogen Free	IEC 60754-1; EN 50267-2-1; DIN VDE 0482-267-2-1; CEI 20-37/2-1 ; BS 6425-1*
No Corrosive Gas Emission	IEC 60754-2; EN 50267-2-2; DIN VDE 0482-267-2-2; CEI 20-37/2-2 ; BS 6425-2*



Minimum Smoke Emission	IEC 61034-1&2; EN 61034 -1&2; DIN VDE 0482-1034-1&2; CEI 20-37/3-1&2; EN 50268-1&2*; BS 7622-1&2*
No Toxic gases	NES 02-713; NF C 20-454

Note: Asterisk * denotes superseded standard.

VOLTAGE RATING

600/1000 V

CABLE CONSTRUCTION

Conductors: Plain annealed copper wire, stranded for section up to 10mm² according to IEC 60228 class 2 or flexible for section above 10mm² according to IEC 60228 class 5.

Insulation: Fire resistant silicone rubber compound type EI2 as per BS 7655-1.1.

Cabling: The cores are cabled together in concentric layers with suitable non-hygroscopic fillers.

Outer Sheath: Thermoplastic LSZH compound type LTS3 as per BS 7655-6.1 (Thermosetting LSZH compound type SW2-SW4 as per BS 7655-2.6 can be offered.). UV resistance, hydrocarbon resistance, oil resistance, anti rodent and anti termite properties can be offered as option.

COLOUR CODE

Insulation Colour:

	Without Earth Conductor
2Cores	Brown, Blue
3Cores	Brown, Gray, Black
4Cores	Brown, Gray, Black, Blue
5Cores	Brown, Gray, Black, Blue, Black

Sheath Colour: Colour red or white (other colours on request)

PHYSICAL AND THERMAL PROPERTIES

Temperature range during operation (fixed state): -30°C – +90°C

Temperature range during installation (mobile state): -20°C – +50°C

Minimum bending radius: 6 x Overall Diameter

ELECTRICAL PROPERTIES

Dielectric test:	3500 V r.m.s. x 5' (core/core)
Insulation Resistance	≥300 MΩ x km (at 20°C)
Short circuit Temperature	350°C

CONSTRUCTION PARAMETERS

Cable Code	No. of Core X Cross Section	Nominal Insulation Thickness	Nominal Sheath Thickness	Nominal Overall Diameter	Approx. Weight
	mm ²	mm	mm	mm	kg/km
2 core					
FFX400 1SZ1-R(PH60)	2x1.5	1.0	1.2	9,2	124
FFX400 1SZ1-R(PH60)	2x2.5	1.1	1.3	10,0	155
FFX400 1SZ1-R(PH60)	2x4.0	1.1	1.4	11,2	207
FFX400 1SZ1-R(PH60)	2x6.0	1.1	1.5	13,1	298
FFX400 1SZ1-F(PH60)	2x10	1.1	1.6	15,9	441
FFX400 1SZ1-F(PH60)	2x16	1.1	1.7	17,4	602
3 core					
FFX400 1SZ1-F(PH60)	3x1.5	1.0	1.2	9,8	148
FFX400 1SZ1-F(PH60)	3x2.5	1.1	1.3	10,6	188
FFX400 1SZ1-F(PH60)	3x4.0	1.1	1.4	12,1	263
FFX400 1SZ1-F(PH60)	3x6.0	1.1	1.5	14,4	372
FFX400 1SZ1-F(PH60)	3x10	1.1	1.6	16,8	541
FFX400 1SZ1-F(PH60)	3x16	1.1	1.7	19,4	777
4 core					
FFX400 1SZ1-F(PH60)	4x1.5	1.0	1.3	10,6	176
FFX400 1SZ1-F(PH60)	4x2.5	1.1	1.4	11,5	228
FFX400 1SZ1-F(PH60)	4x4.0	1.1	1.5	13,6	332
FFX400 1SZ1-F(PH60)	4x6.0	1.1	1.6	11,5	214
FFX400 1SZ1-F(PH60)	4x10	1.1	1.7	18,5	680
FFX400 1SZ1-F(PH60)	4x16	1.1	1.8	21,2	973
5 core					
FFX400 1SZ1-F(PH60)	5x2.5	1.1	1.4	12,6	266
FFX400 1SZ1-F(PH60)	5x4.0	1.1	1.5	14,5	399
FFX400 1SZ1-F(PH60)	5x6.0	1.1	1.6	17,6	576
FFX400 1SZ1-F(PH60)	5x10	1.1	1.7	20,5	850
FFX400 1SZ1-F(PH60)	5x16	1.1	1.8	23,3	1202

ELECTRICAL PROPERTIES

Conductor Operating Temperature : 90°C

Ambient Temperature : 30°C

Current-Carrying Capacities (Amp)



Nominal Cross Section Area	Reference Method 4 (enclosed in an conduit insulated wall etc)	Reference Method 3 (enclosed in conduit on a wall or ceiling, or in trunking)		Reference Method 1 (clipped direct)		Reference Method 11 (on a perforated cable tray), or Reference Method 13 (free air)	
	one 3-core cable or one 4-core cable 3-phase a.c.	one 2-core cable single phase a.c. or d.c.	one 3-core cable or one 4-core cable 3-phase a.c.	one 2-core cable single phase a.c. or d.c.	one 3-core cable or one 4-core cable 3-phase a.c.	one 2-core cable singlephase	one 3-core cable or one
						a.c. or	4-core cable
						d.c.	3-phase a.c.
1	2	3	4	5	6	7	8
mm ²	A	A	A	A	A	A	A
1.5	16.5	22	19.5	24	22	26	23
2.5	22	30	26	33	30	36	32
4	30	40	35	45	40	49	42
6	38	51	44	58	52	63	54
10	51	69	60	80	71	86	75
16	68	91	80	107	96	115	100

Voltage Drop (Per Amp Per Meter)

Nominal Cross Section Area	2-core cable d.c.	2-core cable single-phase a.c.	3-core or 4-core cable 3-phase a.c.
1	2	3	4
mm ²	mV/A/m	mV/A/m	mV/A/m
1.5	31	31	27
2.5	19	19	16
4	12	12	10
6	7.9	7.9	6.8
10	4.7	4.7	4
16	2.9	2.9	2.5

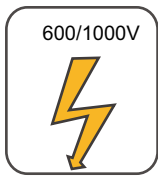

Rated Voltage



Standard

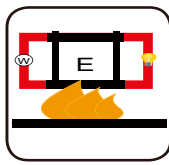

Circuit Integrity
IEC 60331/BS 6387
EN 50200
NF C32-070-2.3(CR1)



Reduced Fire Propagation
NF C32-070-2.2(C1)
IEC60332-3-24/EN50266-2-4



Flame Retardancy
NF C32-070-2.1(C2)
IEC60332-1-2/EN50265-2-1



Low Toxicity
NES 02-713/NF C 20-454



Low Corrosivity
IEC60754-2
EN50267-2-2/3
NF C 32-074



Low Smoke Emission
IEC 61034-1&2
EN 50268-1&2/NF C32-073

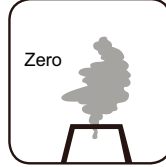

Halogen Free
IEC60754-1
EN50267-2-1

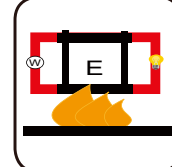

Functional Integrity
DIN 4102-12

TYPE CODES FOR FIRE RESISTANT POWER & CONTROL CABLES

FFXA-B-C-D-E

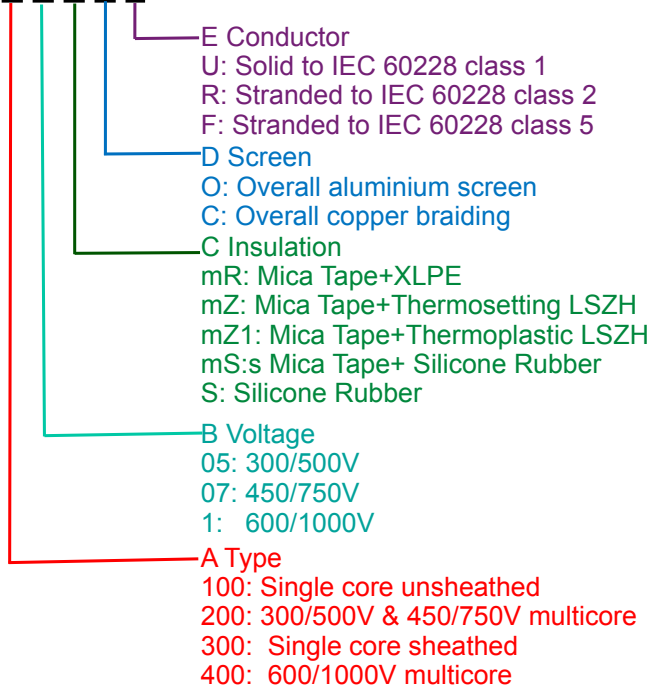



Address:

**Marchants Industrial Centre, Mill Lane, Laughton, Lewes,
East Sussex, BN8 6AJ, UK**

Tel: 44(0) 207 4195087

Fax: 44(0) 207 8319489

E-mail: sales@caledonian-cables.co.uk

www.caledonian-cables.co.uk

Address:

Marchants

Industrial

Centre,

Mill Lane,

Laughton,

Lewes,

East Sussex,

BN8 6AJ, UK

Tel: 44(0) 207 4195087

Fax: 44(0) 207 8319489

E-mail: sales@caledonian-cables.co.uk

www.caledonian-cables.co.uk

